

autodin

MESSAGE CONCENTRATOR

17 AUGUST 1964

A PROPOSAL FROM

UNIVAC
DIVISION OF SPERRY RAND CORPORATION

PROPOSAL FOR A
MESSAGE CONCENTRATOR CENTER

PROPRIETARY NOTICE

This document contains information which is proprietary in nature to the UNIVAC Division, Sperry Rand Corporation and which is furnished for the exclusive use of the recipient. It is requested that the information contained not be discussed with persons not within the confines of the receiving organization.

TABLE OF CONTENTS

Letter of Transmittal

Section 1 - Introduction

Section 2 - Summary of Approach

- 2.1 Message Concentrator Summary
- 2.2 Hardware Summary
- 2.3 Modularity
- 2.4 System Performance

Section 3 - Hardware Description

- 3.1 Conus 24
- 3.2 MH-160 Magnetic Drum Subsystem
- 3.3 Standard Communication Subsystem
- 3.4 Uniservo VI-C Magnetic Tape Units

Section 4 - Programming

- 4.1 Exec
- 4.2 Communication Input Subroutine
- 4.3 Intransit Subroutine
- 4.4 Reference Subroutine
- 4.5 Journal Subroutine
- 4.6 Communication Output Subroutine
- 4.7 ART Assembly System
- 4.8 Conus 24 Subroutines

Section 5 - System Operation

SECTION 1

INTRODUCTION

The UNIVAC Division recognized very early the requirements for an efficient Message Concentrator for AUTODIN, and an intensive program has been supported in the UNIVAC Engineering Center in St. Paul, Minnesota to develop modern, reliable, and economical equipment which will meet these requirements. The results of this program are presented in this unsolicited proposal.

In addition to defining equipment for this AUTODIN requirement, the UNIVAC development program has also included the preparation of the necessary software for a complete AUTODIN Message Concentrator. This concentrator has been designed for compatibility with the present AUTODIN/CONUS System as well as the new overseas AUTODIN System using ASCII Code.

This AUTODIN Message Concentrator will connect a number of tributary circuits into one or more AUTODIN centers by means of high speed Mode 1, continuous mode trunk circuits. The proposed concentrator may function as a pure concentrator/distributor or it may be assigned the additional responsibility of tributary message switching center independent of the main AUTODIN Centers. There are many immediate advantages which are accrued from such a system philosophy. Among these advantages are the increased efficiency of the large AUTODIN Centers since circuits which terminate in the AUTODIN Center will be all high speed circuits. Thereby permitting the maximum utilization of the AUTODIN Center's throughout capacity and a reduction of circuit mileage and cost while permitting additional subscribers to have AUTODIN access. The most important asset of this system philosophy is a significant increase in system survivability. A network comprised of many small concentrators rather than a network comprised of only a few large centers creates an absolute minimum of major target areas and allow maximum circuit diversification to be employed.

The development program for the AUTODIN Message Concentrator has included every aspect of the stringent UNIVAC reliability program, and the modularity of the developed equipment and software will permit complete freedom in systems design. Finally, the UNIVAC Division has expended considerable effort to anticipate all Government requirements and specifications. The entire UNIVAC development program has been based on the successful realization of these anticipated needs.

SECTION 2

SUMMARY OF APPROACH

In this section, a summary of the UNIVAC Message Concentrator is provided with appropriate cross references to the detailed proposal.

2.1 MESSAGE CONCENTRATOR SUMMARY

The UNIVAC Division propose a Message Concentrator which may be employed in either of two functional applications. These applications are a Message Concentrator with intra-concentrator switching and Message Concentrator without intra-concentrator switching. The former application is actually a minor switch as well as a message concentrator and as such it must maintain the necessary records and processing procedures prescribed for an AUTODIN Center for all intra-concentrator messages. A pure message concentrator, however, will not process any messages that are not also processed by an AUTODIN Center. As such, the pure message concentrator may relax certain AUTODIN procedures since they will be performed by the associated AUTODIN Center. This relaxation of certain AUTODIN procedures however does not mean to imply that the pure Message Concentrator will take exception to any requirements which ensure the security, integrity, and compatibility of messages being transmitted.

Since there are two functional applications envisioned, there are two equipment configurations proposed to satisfy this system philosophy. Figures 2-1 and 2-2 present these configurations assuming a hypothetical number of tributary and trunk circuits for purposes of illustration.

This UNIVAC Message Concentrator has been designed to be compatible with all transmission modes of the AUTODIN System particularly Mode I and Mode V transmission procedures. The communication peripheral equipment will automatically provide any transmission speed conversion and the operational software will process the various transmission codes, performing any necessary translation so that all messages on the AUTODIN trunk (s) will be in Fielddata code (AUTODIN Version) for AUTODIN/CONUS Centers and ASCII Code for overseas AUTODIN Centers.

2.1.1 CONUS 24 •

The UNIVAC CONUS 24 is a powerful stored program general purpose communication processor. The unit provides the heart of the proposed Message Concentrator for either functional application. The basic word length of this processor is 24 bits which can be addressed in 8 bit bytes thereby providing immediate compatibility to the 8 bit character used in the AUTODIN Centers. The magnetic core memory, which has a cycle time of 2.5 micro-

seconds, is provided in increments of 4096 words and may be field expanded to a total memory capacity of 65,536 words.

Access into and out of the UNIVAC CONUS 24 processor is provided by three duplex input/output channels. These three basic input/output channels may be readily expanded to three additional channels for a total of six duplex input/output channels so that the system may expand as the requirements grow.

The instruction repertoire has been derived and defined as a direct result of UNIVAC's long and successful history in computer communication systems. UNIVAC has isolated those functions which are continually required for a communication application and has specified special program instructions for these functions. An instruction repertoire which is communication oriented coupled with a fast, highly efficient processor provides the user with an extremely powerful communication system. A complete detailed discussion of this instruction repertoire is presented in Section 3 of this proposal.

The logic design of the UNIVAC CONUS 24 is the end result of a new hardware engineering approach to computer design. This design technique which is unique to the CONUS 24 results in a physically small and economical processor. The entire CONUS 24 including the basic magnetic core memory, input/output and memory controls contain less than 200 printed circuit cards and weighs less than 100 lbs. The complete UNIVAC CONUS 24 may be easily mounted on a single standard 19 inch rack including the power supplies.

2.1.2 STANDARD COMMUNICATION SUBSYSTEM

The direct interface between the various communication circuits and the UNIVAC CONUS 24 processor is provided by the UNIVAC Standard Communication Subsystem. This equipment, which is currently in operation in many Government and commercial applications allows the central processor to function most efficiently as a communication system. The UNIVAC Standard Communication enables the CONUS 24 to exchange data simultaneously with a number of remote locations over communication circuits. This subsystem consists of a Communication Multiplexer which allows up to 64 simplex communication circuits to share a computer Input/Output channel and Communication Line Terminals which properly terminate the communication circuits and provide data conversion (bit serial to bit parallel) to achieve compatibility with the CONUS 24.

The outstanding features of this Standard Communication Subsystem are flexibility, modularity, reliability and speed with the resulting advantage of economy. A detailed discussion of the operation of this unique equipment is presented in Section 5 of this proposal.

The UNIVAC Standard Communication Subsystem consists of two principal elements: Communication Line Terminals (CLTs), which establish direct connection with the communications facilities; and the Communication Multiplexers, through which the CLTs deliver data to or receive data from the CONUS 24. A third element, Scanner Selectors, may also be employed for special high volume applications.

1. Communication Line Terminals (CLTs)

There are three basic kinds of input and output CLTs: low speed (up to 300 bits per second); medium speed (up to 1600 bits per second); and high speed (2000 to 4800 bits per second). Each is easily adjusted to the speed and other characteristics of the communications line with which it is to operate. Each CLT requires one position, either input or output, of the Communication Multiplexer. Figure 2-3 presents a listing of the available Communication Line Terminals.

The Communication Multiplexer functions as the link between the processor and the CLT's and is available in modules to handle 4,8,16,32, or 64 CLT's. In each of these modules, an equal number of input and output CLT positions are provided. For example, a 64 position Communication Multiplexer can accommodate up to 32 input and up to 32 output CLT's.

One or more Communication Multiplexers may be connected to an input/output channel through a Scanner Selector. The total number of Communication Multiplexers which may be connected to any channel or to any system is dependent on the number, speed and activity of the communication lines linked to the Communication Multiplexer. Figure 2-3 presents a listing of available Communication Multiplexers.

In cases where more than one Communication Multiplexer is used on a single input/output computer channel, a Scanner Selector must be employed to control the simultaneous operation of the multiplexers. A maximum of four multiplexers may be connected to one Scanner Selector as illustrated in Figure 2-4.

2.1.2.1 OPERATION

Access to the Central Processor input/output channel is granted only when a Communication Line Terminal requests such access. Any data transfer, input or output, is therefore initiated by the Communication Line Terminal since only it responds directly to its associated communication line's data needs. Since the data volumes and transmission rates (bits or characters per second) may be completely variable for a number of communication lines associated with a Communication Multiplexer, the Communication Line Terminals will initiate data transfers in a completely random pattern over a given

UNIVAC MESSAGE CONCENTRATOR WITH INTRA-CENTRATOR SWITCHING

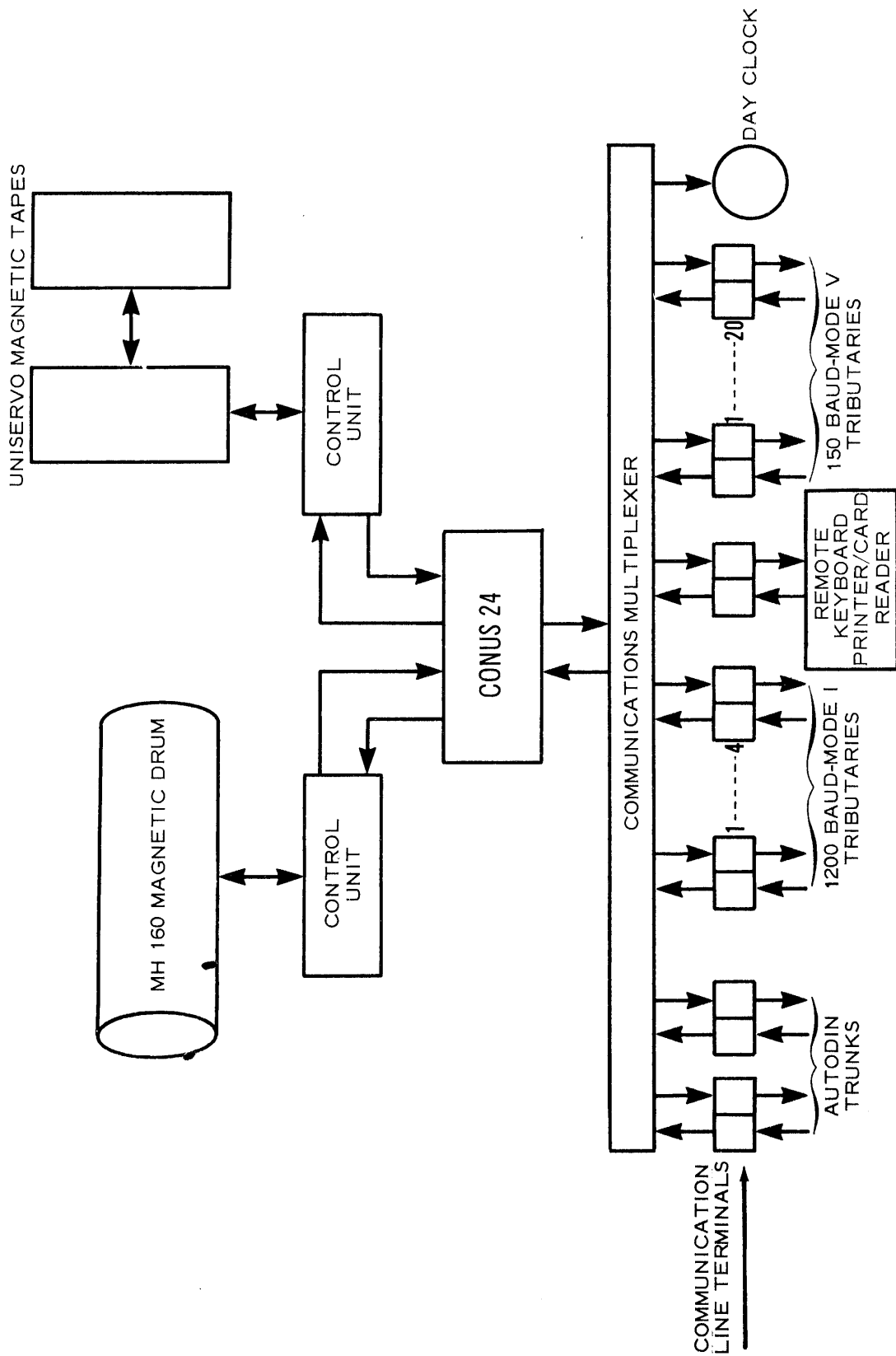

FIGURE 2 - 1

UNIVAC MESSAGE CONCENTRATOR
WITHOUT INTRA-CONCENTRATOR SWITCHING

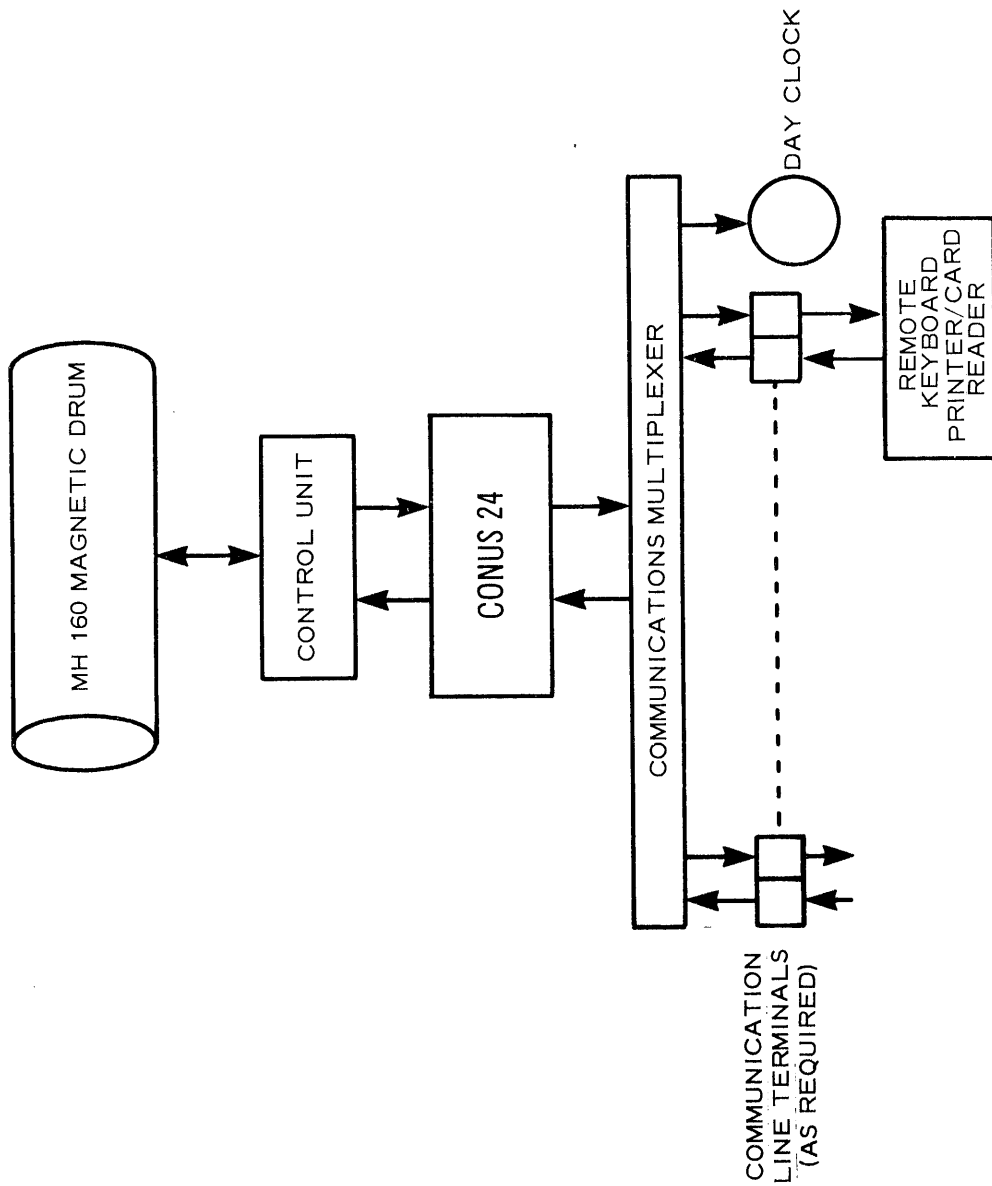

FIGURE 2 - 2

INPUT COMMUNICATION LINE TERMINALS (CLT's)

	Low Speed		Medium Speed		High Speed
Name	CLT51L	CLT81L	CLT81M	CLT81P	CLT81H
Code	5 Level	6,7, or 8 Level	5,6,7, or 8 Level	8 Level	5,6,7, or 8 Level
Mode	*Asynchronous	Asynchronous	Asynchronous	***Timing Signal	**Synchronous
Speed	Bit Serial	Bit Serial	Bit Serial	Bit Parallel	Bit Serial
	Up to 300 bps	Up to 300 bps	Up to 1600 bps	Up to 75 cps	2400-4800 bps

OUTPUT COMMUNICATION LINE TERMINALS (CLT's)

	Low Speed		Medium Speed		High Speed	† Dialing
Name	CLT50L	CLT80L	CLT80M	CLT80P	CLT80H	CLT Dialing
Code	5 Level	6,7, or 8 Level	5,6,7, or 8 Level	8 Level	5,6,7, or 8 Level	4 Level
Mode	Asynchronous	Asynchronous	Asynchronous	Timing Signal	Synchronous	Timing Signal
Speed	Bit Serial	Bit Serial	Bit Serial	Bit Parallel	Bit Serial	Bit Parallel
	Up to 300 bps	Up to 300 bps	Up to 1600 bps	Up to 75 cps	2000-4800 bps	Variable

COMMUNICATION MULTIPLEXER

Name	Function
C/M-4	Connects 2 input and 2 output CLT's to General Purpose Channel
C/M-8	Connects 4 input and 4 output CLT's to General Purpose Channel
C/M-16	Connects 8 input and 8 output CLT's to General Purpose Channel
C/M-32	Connects 16 input and 16 output CLT's to General Purpose Channel
C/M-64	Connects 32 input and 32 output CLT's to General Purpose Channel

Fig. 2-3. UNIVAC Standard Communication Subsystem Characteristics

† CLT - Dialing - This is an output CLT employed when the Central Processor is automatically to establish communications with remote points via the common carrier's switching network.

*ASYNCHRONOUS - Employs start and stop bit with each character to establish timing.

**SYNCHRONOUS - Uses timing characters at pre-determined intervals between data characters.

***TIMING SIGNAL - Indicates the presence of a character at a modem.

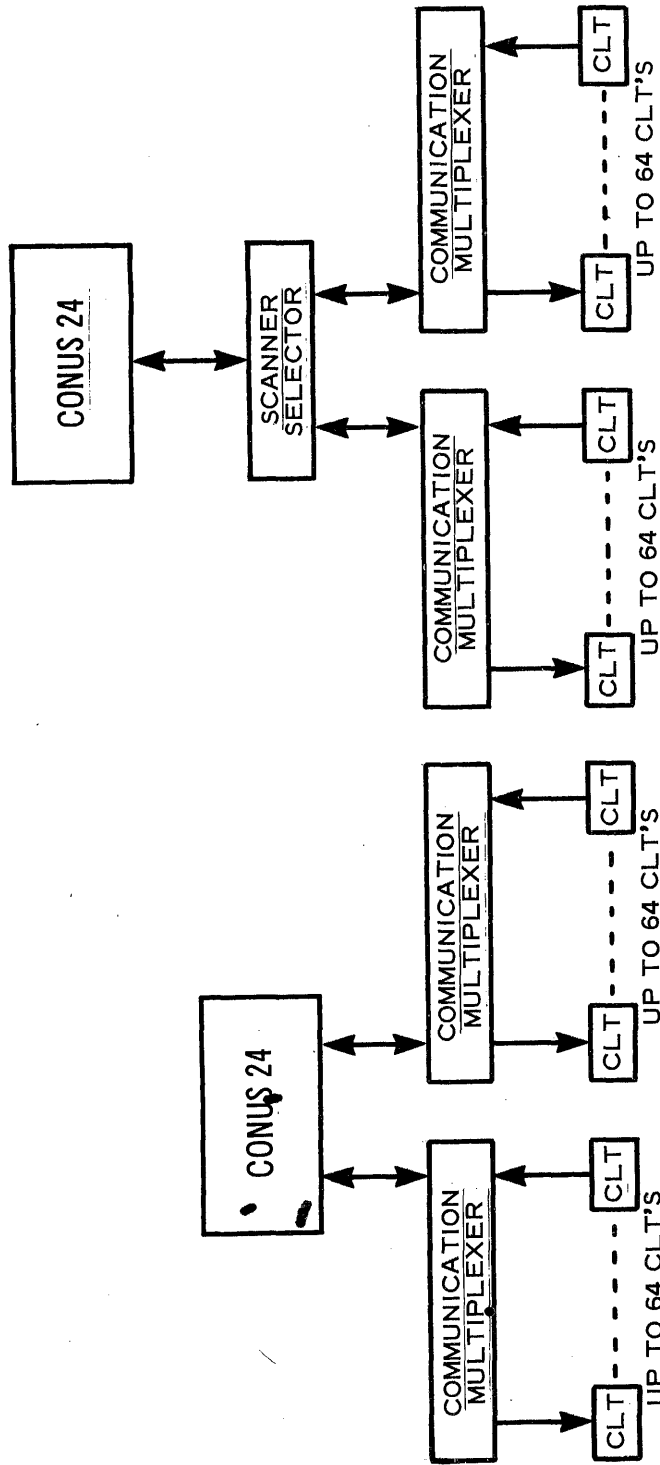

ONE COMMUNICATION MULTIPLEXER
PER GENERAL PURPOSE CHANNEL

MULTIPLE COMMUNICATION MULTIPLEXERS PER
GENERAL PURPOSE CHANNEL USING SCANNER SELECTOR

UNIVAC STANDARD COMMUNICATION SUBSYSTEM
EXPANSION CAPABILITY

FIGURE 2 - 4

UNIVAC 1068

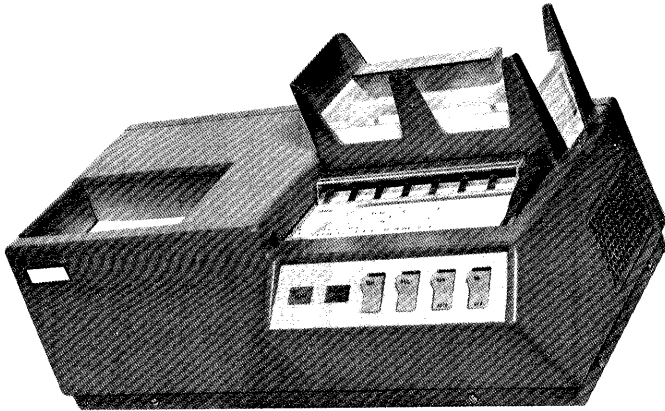

CARD READER: 7.5 CARDS PER MINUTE

REMOTE KEYBOARD PRINTER/CARD READER

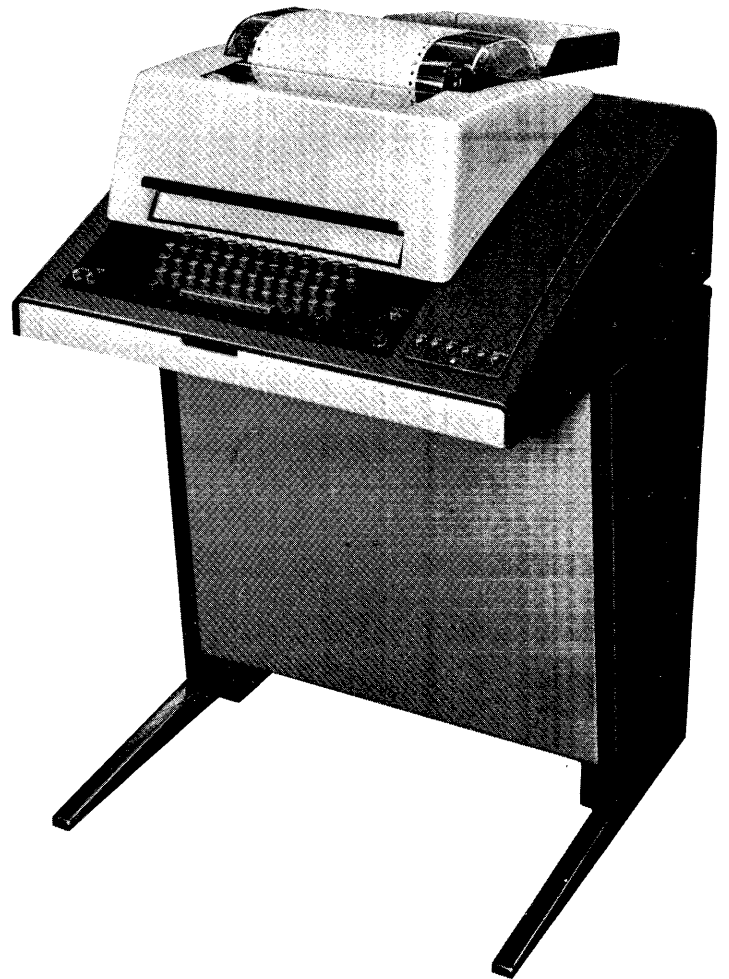

FEATURES

- Standard 4-row typewriter keyboard
- 10 characters per second print
- Pin-feed form control
- 8-level code
- 300 bits per second transmit/receive speed
- Visual edit of complete message before release to computer
- Receives solicited and unsolicited responses

period of time. Therefore, the Communication Multiplexer must identify, in a unique way, the Communication Line Terminal requesting the data transfer each time an access is made to the processor input/output channel. This identification is accomplished by an Externally Specified Index Address (ESI Address).

Each Communication Multiplexer is capable of generating 64 unique ESI Addresses. The ESI Address consists of 15 bits which are transferred to the Central Processor with each input data transfer and with each request for output data. The six low order bits of the ESI Address originate at a specific CLT. These six bits are fixed in the sense that each of the 64 positions of the Communication Multiplexer is permanently wired to generate a unique six bit code. The remaining nine high order positions of the ESI Address are plugboard wired and may be varied to meet the user's requirements.

The UNIVAC Standard Communication Subsystem has been designed to handle a multiplicity of different speed communications facilities in the most efficient manner possible. The Communication Multiplexer contains priority logic which permits high speed facilities to be serviced more frequently than low speed facilities on a completely random basis. Each of the 64 positions of the Communication Multiplexer has a number (00-77 octal) which is used to establish service priority. Input CLTs are connected to the odd numbered positions while output CLTs are connected to the even numbered positions. The Communication Multiplexer simultaneously samples all CLTs requesting service and grants service priority to the CLT connected to the highest numbered position, regardless of whether it is input or output. After each data transfer, all service requests are re-examined to determine the highest remaining priority.

2.1.3 MH-160 MAGNETIC DRUM

Both functional applications will use a random access storage in the form of a UNIVAC MH-160 Magnetic Drum. This high density storage medium will be used primarily to accumulate the data blocks of messages which are being transmitted between the originator and the desired addressee (s). This magnetic drum will be referred to as the In-Transit Storage. When the proposed equipment is being employed as a pure message concentrator without intra-concentrator switching, the UNIVAC MH-160 Magnetic Drum will store an entire input message before the output transmission is initiated. This procedure is basically required since an incoming message may be delayed by a WBT/REP Sequence or even prematurely terminated by a RM/DM Sequence. Since the maximum length of an input message may vary from 6900 characters for a teletypewriter to 40,000 characters for a high speed Mode I terminal, these messages cannot be possibly retained in the magnetic core memory of the CONUS 24 and still achieve the economic objective.

In both functional applications the UNIVAC MH-160 Magnetic Drum will also provide immediate reference storage for message retrieval and a journal storage for traffic statistics. As a message concentrator with intra-concentrator switching, there will be some messages whose transmission will never be recorded in the AUTODIN Switching Center. The reference and journal storage of these messages will eventually be transferred to magnetic tape units discussed under heading 2.1.4 below.

The UNIVAC MH-160 Magnetic Drum has an internal storage capacity of over 9.4 million characters. Access to and from these characters is executed by way of 11 head blocks which contain 14 channels each for a total of 154 channels of which 128 are used for data and 26 are used for spares and timing. These head blocks have a total of 12 positions so that in any position over 783,000 characters are directly under all heads. The average access time for any of these 783,000 characters is 17 milliseconds. Head block positioning time is approximately 40 milliseconds which is only incurred when the head blocks are moved between two adjacent 783,000 character sectors.

2.1.4 UNISERVO VFC MAGNETIC TAPE UNITS

The UNISERVO VFC Magnetic Tape Units are proposed for the functional application in which the UNIVAC Message Concentrator will perform intra-concentrator message switching. If a message is received from a tributary destined for another tributary associated with this same CONUS 24, the delivery of that message will be performed without involvement of the associated AUTODIN Center. Since this message never actually entered the AUTODIN System, the only place where a reference and journal entry would be made is at the UNIVAC Message Concentrator. In this functional application, a permanent reference and journal storage would be maintained on a UNISERVO Magnetic Tape Unit.

The UNISERVO Magnetic Tape Unit provides the capability of reading and writing compatible magnetic tapes at densities of 200, 556, and 800 characters per inch in the NRZ1 fashion.

The data transfer rate of up to 34,160 characters per second is more than adequate for the message concentrator function. Data checking includes character parity (odd or even at the program's option), longitudinal parity and a read-after-write check to ensure complete message protection for all data transfers.

2.2 HARDWARE SUMMARY

The proposed UNIVAC Message Concentrator may be provided for two functional applications. A brief hardware summary for each of these applications is presented below. Each unit of equipment is presented with their general operating characteristics. A cross reference is also included to the portion of this proposal in which the equipment is discussed in detail.

A UNIVAC Message Concentrator which will also be required to perform intra-concentrator message switching has the following equipment.

Item	Equipment	Characteristics	Proposal Heading
1	CONUS 24	Internally Stored Program Communication Processor with up to 65,536 24 bit word memory cycle time of 2.5 microseconds. Basic three input/output channels with the option for an additional three.	3.1
2	MH-160 Magnetic Drum	9.4 million 8 bit characters of storage with an average access time of 17 milliseconds per 783,000 character sector.	3.2
3	UNISERVO VIC Magnetic Tape Units	200, 556 or 800 characters per inch with a data transfer rate of 34,160 characters per second.	3.4
4	Standard Communication Subsystem	Comprised of a Communication Multiplexer and a family of Communication Line Terminals which are unique to an application.	3.3

A UNIVAC Message Concentrator which does not perform any intraconcentrator message switching has the following equipment:

Item	Equipment	Characteristics	Proposal Heading
1	CONUS 24	Internally Stored Program Communication Processor with up to 65,536 24 bit word memory having a memory cycle time of 2.5 microseconds. Basic three input/output channels with the option for an additional three.	3.1

2	MH-160 Magnetic Drum	9.4 million 8 bit characters of storage with an average access time of 17 milliseconds per 783,000 character sector.	3.2
3	Standard Communication Subsystem	Comprised of a Communication Multiplexer and a family of Communication Line Terminals which are unique to an application.	3.3

2.3 MODULARITY

The proposed UNIVAC Message Concentrator has been designed with maximum modularity and hence flexibility so that it would readily satisfy all possible application areas and be readily capable of expanding as the communication environment grows. Heading 2.1 while briefly discussing each of the equipments also pointed out the inherent modularity of each unit.

The central unit of the proposed configuration is the UNIVAC CONUS 24 Communication Processor. This unique processor is modular with respect to memory and Input/Output channels. The basic processor has a memory of 4096 24 bit words. Expansion of the memory in 4096 word modules is field installable up to a maximum of 65,536 24 bit words. The Input/Output channels may also be readily expanded from the basic three duplex channels to a maximum of six duplex Input/Output channels. This Input/Output channel modularity will permit connection of additional peripherals, such as, MH-160 Magnetic Drums or Standard Communication Subsystems as the demand for service to more remote data communication terminals increases.

The UNIVAC Standard Communication Subsystem represents the ultimate in equipment modularity. The basic Communication Multiplexer is modular with respect to the number of available positions, that is, 4, 8, 16, 32, or 64 simplex Communication Line Terminal positions. The modular family of available Communication Line Terminals provides a user with compatibility to virtually every possible data transmission procedure. By the inclusion of the Scanner Selector, four full capacity Communication Multiplexers may be concurrently connected to a single Input/Output channel thereby providing another degree of modularity.

The UNIVAC MH-160 Magnetic Drum and the UNISERVO Magnetic Tape Units may be connected to the Input/Output channels on the UNIVAC CONUS 24 Communication Processor. An example of the overall modularity of the UNIVAC equipment and system engineering is typified by the fact that in lieu of the UNISERVO Magnetic Tape Control Unit (Figure 2-1) a UNIVAC 1004 may be employed automatically providing the user with high speed on-line

printing and full punch card capability. This additional ability may be used for such functions as statistical traffic analysis or even for data processing not necessarily related to the communication function. In the latter application, use may be made of available time and core in the CONUS 24 in addition to the UNIVAC 1004. Even for the functional applications which do not require the UNISERVO Magnetic Tape, a UNIVAC 1004 may be readily connected to the proposed Message Concentrator for data processing functions.

Efficient modularity at the system, unit, and component levels is provided in all possible configurations of the proposed UNIVAC Message Concentrator for the AUTODIN System.

2.4 SYSTEM PERFORMANCE

The actual system performance and utilization is summarized in this section with a discussion of the hypothetical Message Concentrator configuration employed. A detail derivation of these statistics is presented later in Section 5 of this proposal.

The system assumptions for the hypothetical message concentrator configuration have been derived as being typical of the type of environment which would be experienced. These assumptions are presented below:

1. Circuits

20 - 150 baud full duplex, local tributaries, Modes I and V.

4 - 1200 baud full duplex, local tributaries, Mode I (block-by-block).

2 - 2400 baud full duplex, AUTODIN Trunks, Mode I (continuous mode).

2. Average circuit utilization is 60 percent.

3. Average local inputs for local distribution is 20 percent when the functional application includes intra-concentrator switching.

4. Address multiplicity is 1.75 addresses per message.

A Message Concentrator may be divided into two independent internal functions. The concentrator function which gathers messages from the tributaries and transmits them multiplexed on a message basis to an AUTODIN Center by way of a trunk circuit. The distributor function receives messages from the AUTODIN Center and delivers these messages to the desired tributaries. Each of these internal functions will be analyzed for the peak and average minute.

With the concentration function for the average minute, the tributaries will develop a total of 12.55 messages per minute for an average of 26,351.64 characters. Since the total output capacity to AUTODIN is 36,000.00 characters minus acknowledge's for the distribution function, the spare capacity to AUTODIN is 9,134.08 characters per minute. In the peak minute the tributaries will develop a total of 20.58 messages per minute for an average of 43,218.00 characters. Using the same total output capacity to AUTODIN the peak minute will add to the intransit storage on the MH-160 Magnetic Drum at the rate of 8,055.20 characters per minute.

The distribution function will develop 23.31 messages for transmission to the tributaries during the average minute. These messages are assumed to be evenly distributed as to circuit speed; therefore, the Mode I tributaries will receive 15.62 messages for an average of 32,802.00 characters and the Mode V tributaries will receive 7.69 messages for an average of 15,380.00 characters. After deducting required acknowledge's from Mode I and Mode V output capacities the spare capacity is 2,683.72 and 2,609.20 characters respectively. In the peak minute the distribution function will develop 38.22 messages for transmission to the tributaries. Assuming the same distribution as the average minute, the Mode I tributaries will receive 25.61 messages for an average of 53,781.00 characters and the Mode V tributaries will receive 12.61 messages or 25,220.00 characters.

Deducting the required acknowledge's from the output transmission capacity, the distribution function adds to the intransit storage on the MH-160 Magnetic Drum at the rate of 18,618.20 characters per minute for Mode I tributaries and 7,238.00 characters per minute for Mode V tributaries.

Analysing the trunk lines to the AUTODIN Center the peak minute develops 8,055.20 characters in excess of line capacity. Since the average minute has spare capacity of 9,134.08 characters no queuing will ensue if there is at least one time unit of average activity for every time unit of peak activity.

The Mode I tributaries develop an excess of 18,618.20 characters per minute during peaks and have 2,683.72 characters per minute spare during averages which dictates a ratio of 7 to 1 for averages vs. peaks.

The Mode V tributaries develop 7,238.00 characters per minute over capacity during peak minutes with 2,609.20 spare character capacity during averages. This would require at least three time periods of average activity for every time period of peak.

On the intransit storage there will be areas to contain one message coming into the Message Concentrator from each of the input lines and one message going out to each of the output lines. With an average message size of 2000 characters this area would consist of 104,000 characters. Since during the average period, output capacity is greater than inputs generated, this

figure will be mainly accurate only being affected by multiple addresses on input messages, busy circuit conditions on outputs and by messages of greater than the 2000 character average.

During peak minutes, however, we find input developing which is in excess of output capabilities. Input from all sources could be 33,911.40 characters in excess of the output. Since approximately 3,000,000 characters of magnetic drum storage will be devoted to intransit store, the peak minute may be extended to approximately 85 minutes with no relief prior to resorting to WBT sequences to achieve the necessary ratio of peak vs. average minutes.

The one factor which will determine expansion capability is the time used in the MH-160 Magnetic Storage Drum. During a peak minute the drum is occupied for a total of 38.689 seconds, or 65 percent of the minute. This figure is based on pure average access times and no attempt has been made to reduce average accesses by ordering the data addresses when possible. Until the input volume was increased by 35 percent to 1,215,000 characters per minute the average accessing mechanism would function satisfactorily. When this expanded limit is reached, some portion of the unused program time (32.859 seconds per minute) would be expended to reduce the average accesses per minute.

In timing the program for a peak minute, no attempt was made to write and time the entire processing of an input or output message. Rather than deal in generalities, specific functions which could be planned in detail were selected for examination. These functions are: block parity check or generation, done for every block of data coming into the system; character parity check, control code check, character validity check, transliteration of Mode V characters; all of which must be done for every incoming character; data packing into word format, done on all characters coming into the system to conserve external storage; and data un-packing. All other functions such as queue maintenance, drum thread addressing, and header validation were lumped into miscellaneous housekeeping and estimated at 2000 instruction executions per message. These housekeeping instructions were timed at the maximum execution time of 12.5 microseconds each. Taking all of these factors into consideration we find the total program execution time for a peak minute to be 27.141 seconds. This figure would allow an error in estimation of approximately 20,000 instruction executions, at the maximum time each, for every message and still the time would be less than drum time used. In other words, even with this much error in program time estimates the expansion factor would still be 35 percent.

SECTION 3 HARDWARE DESCRIPTION

A detailed description of each of the devices outlined in section 2 is presented in this section.

3.1 UNIVAC CONUS 24

One of the many outstanding features of the proposed UNIVAC Message Concentrator is the CONUS 24 Communication Processor. This unit exemplifies the high state of the art within UNIVAC for the design and development of communication computer systems. This sophisticated processor is the result of years of operational as well as theoretical engineering experience and studies in the field of computer controlled communication systems.

The CONUS 24 is an internally stored program binary computer with a 24 bit word which is directly compatible with the present 8 bit data communication codes. Not only does the program have the ability to directly address any word in memory but an additional feature permits the programmer to specify the desired 8 bit byte within that word. The CONUS 24, therefore, may be employed as a word computer and also as a character computer at the option of the programmer.

The basic memory consists of 4096 words and may be readily expanded in increments of 4096 word modules to a total of 65,536 words. Thus the basic CONUS 24 may easily grow to meet the requirements of an expanding application. This high speed memory will complete a read and a write operation in 2.5 microseconds per cycle.

The basic CONUS 24 is equipped with three input/output channels which may be expanded to a total of six input/output channels. Since the proposed processor is a communication oriented processor, the design technique which allows communication data to be transferred by way of the input/output channel is of significance when attempting to evaluate the system as acceptable. The CONUS 24 uses an engineering technique called the Externally Specified Index (ESI) when dealing with the communication circuits by way of the Standard Communication Subsystem. This technique allows each character to be located in a unique buffer area within the CONUS 24's internal core memory. These buffer areas are each unique to a particular communication circuit. The locating and accessing of a data character to be transmitted on a particular communication circuit or the writing of a data character just received into a particular memory location is performed by the input/output channel hardware and the Standard Communication Subsystem. The

actual program is not interrupted or involved in any way for individual data character transfers. With this technique the actual program execution is performed without interruption other than for necessary core cycles as the individual data characters are being concurrently accessed from and written into the CONUS 24 internal core memory.

The instruction repertoire has been derived from UNIVAC's past communication experience to include program instructions which would perform the functions most required by a computer-controlled communication system. Table 3-1 presents the available instructions for the CONUS 24 Communication Processor.

The actual function of these instructions with the average and maximum instruction execution times are present in Table 3-2.

3.2 UNIVAC MH-160 MAGNETIC DRUM

The MH-160 Magnetic Drum Subsystem is a word addressable drum unit having a data capacity of 9.4 million (eight bit byte) characters. The Drum Subsystem is designed with a single movable shaft which supports ten flying data head blocks and associated loading/lifting hardware. An additional shaft supports a single timing head. A standard head block with 14 channels are used to give the proper head center to center spacing. Eleven such 14 channel head blocks are used to give 154 total heads, of which 128 are used for data. The remaining 26 heads are used for spares and timing. An open loop pneumatic binary ram is utilized to position the heads and head loading shaft to any one of twelve positions. The pneumatic binary ram is referred to as an open loop servo having no need for feedback. The positions are maintained by relatively high forces against mechanical stops rather than the typical "force per error displacement" null characteristics found in a closed loop servo. Of prime importance is that 1/12 of the total capacity consisting 783,333 bytes may be word addressed with an average access time of 17 milliseconds.

The following transfer rates are available and can be selected by manually interchanging special cards in the control units.

- a. 60,000 words/sec. (180 KC byte rate)
- b. 30,000 words/sec. (90 KC byte rate)
- c. 15,000 words/sec. (45 KC byte rate)

Data words received from the CONUS 24 are recorded in successive addresses on the drum, beginning at the address specified in the External Function words. Writing will stop when:

- a. No more data words are received from the computer.
- b. The last storage address on the drum has been recorded in.
During peak I/O loads, if a word is received too late to be recorded on the drum during the current revolution, it will be held in the control unit and written on the next revolution.

CONUS 24

INSTRUCTION REPERTOIRE

<u>MNEMONIC</u>	<u>OCTAL</u>	<u>FUNCTION NAME</u>
STP	00	STOP
SAD	01	STORE PROGRAM STATUS
LAD	02	LOAD PROGRAM STATUS
EXC	03	EXECUTE REMOTE
RJP	04	SET RETURN, EXECUTE REMOTE
MSK	05	MASTER SKIP
JP	06	TRANSFER CONTROL
SCL	07	SET/CLEAR LOCKOUT
ADD	10	ADD
SUB	11	SUBTRACT
LP	12	LOGICAL PRODUCT
SCP	13	SELECTIVE COMPLEMENT
STB	14	STORE INDEX
LDB	15	LOAD INDEX
INB	16	INCREMENT INDEX
CPB	17	COMPARE INDEX
LD	20	LOAD FROM MEMORY
LYU	21	LOAD FROM MEMORY UPPER CHARACTER
LYM	22	LOAD FROM MEMORY MIDDLE CHARACTER
LYL	23	LOAD FROM MEMORY LOWER CHARACTER
CP	24	COMPARE WITH MEMORY
CPU	25	COMPARE WITH MEMORY UPPER CHARACTER
CPM	26	COMPARE WITH MEMORY MIDDLE CHARACTER
CPL	27	COMPARE WITH MEMORY LOWER CHARACTER
ST	30	STORE TO MEMORY
SYU	31	STORE TO MEMORY UPPER CHARACTER
SYM	32	STORE TO MEMORY MIDDLE CHARACTER
SYL	33	STORE TO MEMORY LOWER CHARACTER
INC	40	INCREMENT MEMORY
LDC	41	LOAD CONSTANT
DEC	42	DECREMENT MEMORY, TEST
STA	43	STORE ADDRESS TO MEMORY
LSY	44	SHIFT MEMORY LEFT
LSR	45	SHIFT REGISTER LEFT
TST	46	TEST MEMORY FOR PARITY
RSR	47	SHIFT REGISTER RIGHT
ACI	50	ACTIVATE INPUT CHANNEL
ACO	51	ACTIVATE OUTPUT CHANNEL
EXF	52	EXTERNAL FUNCTION
STC	53	STORE CHANNEL
ESC	60	ESCAPE TO MODE Y

NOTE: All other octal combinations will cause invalid instruction interrupts on the proposed Communications Processor.

<u>OCTAL</u>	<u>INSTRUCTION</u>	<u>FUNCTION</u>	<u>DIRECT</u>	<u>INDIRECT</u>	<u>DESIGNATOR</u>
01	STORE PROGRAM STATUS	The contents of all of the designators are transferred to the low order bit positions of Y.	7.5us	10.0us	CLEAR
02	LOAD PROGRAM STATUS	The contents of the low order bit positions of Y are transferred to the designators. A "1" bit in Y will set the designator "on".	7.5us	10.0us	FILL
05	MASTER SKIP	Test the designator designated by bit position in Y. If the tested designator is set on, skip the next instruction in sequence.	5.0us 7.5us	7.5us 10.0us	HOLD
07	SET/CLEAR LOCKOUT	Set or clear the interrupt lockout as determined by the low order bit position of Y.	5.0us	7.5us	HOLD
14	STORE INDEX	Store the index register designated to memory location Y.	10.0us	12.5us	HOLD
15	LOAD INDEX	Load the index register designated from memory location Y.	10.0us	12.5us	HOLD
16	INCREMENT INDEX	Add the constant from Y to the designated index register.	7.5us	10.0us	HOLD
17	COMPARE INDEX	Compare the designated index register to memory location Y. After comparison, decrement the index register.	12.5us	15.0us	FILL
46	TEST MEMORY	Test the parity bits of memory location Y. Set the carry designator if even parity.	7.5us	10.0us	FILL

TABLE 3-2

Octal	Instruction	Function	Execution Time		Designator Action
			2.5 us Memory		
			<u>i=0</u> Direct	<u>i=1</u> Indirect	
00	STOP	Computer stops if all bits of y are zero. Computer stops if y = 1 and selective stop 1 is set. Computer stops if selective stop 2 is set and y = 1. If computer is restarted, the next instruction in sequence is executed.	5 us	7.5 us	CLEAR
03	EXECUTE	Execute the instruction located at address Y. The main sequence is not affected.	7.5+	10.0+	Variable
04	SET RETURN	The contents of bits 0-15 of the P register are stored in bits 0-15 of memory location Y. The instruction in Y+1 is executed. Y is even number only.	7.5+	10.0+	Variable
06	JUMP	Unconditional jump to Y.	5 us	7.5 us	HOLD
10	ADD Y TO R	The contents of memory location Y are added to the contents of the R register. The sum is placed in the R register.	10 us	12.5 us	FILL
11	SUBTRACT Y FROM R	The contents of memory location Y are subtracted from the contents of the R register. The difference is placed in the R register.	10 us	12.5 us	FILL
12	LOGICAL PRODUCT	The bit-by-bit product of the contents of memory location Y and the R register are stored in the R register.	10 us	12.5 us	FILL
13	SELECTIVE COMPLEMENT	Complement the individual bits of the R register corresponding to one's (1's) in memory location Y.	10 us	12.5 us	FILL

TABLE 3-2

INSTRUCTION OPERATIONS

<u>Octal</u>	<u>Instruction</u>	<u>Function</u>	<u>Execution Time</u>		<u>Designator</u> <u>Action</u>
			<u>2.5 us Memory</u>		
			<u>i=0</u> <u>Direct</u>	<u>i=1</u> <u>Indirect</u>	
20	LOAD R WITH Y	The contents of memory location Y are loaded into the R register.	10 us	12.5 us	FILL
21	LOAD R WITH YU	The contents of bits 16-23 of memory location Y are loaded into bits 0-7 of the R register.	10 us	12.5 us	FILL
22	LOAD R WITH YM	The contents of bits 8-15 of memory location Y are loaded into bits 0-7 of the R register.	10 us	12.5 us	FILL
23	LOAD R WITH YL	The contents of bits 0-7 of memory location Y are loaded into bits 0-7 of the R register.	10 us	12.5 us	FILL
24	COMPARE	The contents of the R register are compared with the contents of memory location Y and the appropriate designator is set.	10.0 us	12.5 us	FILL
25	COMPARE YU	The contents of the R register are compared with bits 16-23 of memory location Y, and the appropriate designator is set.	10.0 us	12.5 us	FILL
26	COMPARE YM	The contents of the R register are compared with bits 8-15 of the contents of memory location Y, and the appropriate designator is set.	10.0 us	12.5 us	FILL
*27	COMPARE YL	The contents of the R register are compared with bits 0-7 of the contents of memory location Y, and the appropriate designator is set.	10.0 us	12.5 us	FILL
30	STORE R IN Y	The contents of the R register are stored in memory location Y.	10 us	12.5 us	HOLD

*NOTE: Comparison does not destroy the contents of either operand.

TABLE 3-2

INSTRUCTION OPERATIONS

<u>Octal</u>	<u>Instruction</u>	<u>Function</u>	<u>Execution Time</u>		<u>Designator</u> <u>Action</u>
			<u>2.5 us memory</u>		
			<u>i=0</u> <u>Direct</u>	<u>i=1</u> <u>Indirect</u>	
31	STORE R IN YU	The contents of bits 0-7 of the A register are stored in bits 16-23 of memory location Y.	10 us	12.5 us	HOLD
32	STORE R IN YM	The contents of bits 0-7 of the R register are stored in bits 8-15 of memory location Y.	10 us	12.5 us	HOLD
33	STORE R IN YL	The contents of bits 0-7 of the A register are stored in bits 0-7 of memory location Y.	10 us	12.5 us	HOLD
40	INCREMENT Y	The contents of memory location Y are incremented by one.	7.5 us	10 us	FILL
41	LOAD CONSTANT	The operand Y (bits 0-13) is loaded into bits 0-13 of the R register. The sign (bit 13) is extended to fill bits 14-23 of the R register.	7.5 us	10 us	FILL
42	DECREMENT Y	The contents of memory location Y are decremented by one. Skip the next instruction if Y final is negative.	7.5 us 10.0 us	10 us 12.5 us	FILL if no skip if skip
43	STORE ADDRESS	The contents of bits 0-15 of the R register are stored in bits 0-15 of memory location Y.	10 us	12.5 us	HOLD
45	SHIFT R LEFT	The contents of the R register are shifted left K places.	5.0 us+	7.5 us+	FILL
47	SHIFT R RIGHT	The contents of the R register are shifted right K places. The higher-order bits are replaced with the original sign bit as the word is shifted.	5.0 us+	7.5 us+	FILL

TABLE 3-2

INSTRUCTION OPERATIONS

<u>Octal</u>	<u>Instruction</u>	<u>Function</u>	<u>Execution Time</u>		<u>Designator</u>
			<u>2.5 us Memory</u>		
			<u>i=0</u>	<u>i=1</u>	
			<u>Direct</u>	<u>Indirect</u>	<u>Action</u>
50	ACTIVATE INPUT CHANNEL	The input channel designated by Y is activated.	5 us	7.5 us	HOLD
51	ACTIVATE OUTPUT CHANNEL	The output channel designated by Y is activated.	5 us	7.5 us	CLEAR
52	EXTERNAL FUNCTION (R) OUTPUT CHANNEL Y	The contents of the R register are transferred to the output channel designated by Y and the External Function line is set.	7.5 us	10.0 us	HOLD
53	STORE CHANNEL (CHANNEL Y) R	The input data lines of the channel designated by Y are sampled and the information is stored in the R register.	7.5 us	10 us	HOLD
60	ESCAPE	Permits the re-ordering of the function codes to include the expanded operation codes.	5.0	7.5	HOLD

Data words are read successive addresses on the drum and transmitted to the CONUS 24. The starting address is specified in the External Function words. Reading stops when:

- a. Data words are no longer acknowledged by the computer.
- b. The contents of the last storage address on the drum has been read.
- c. A parity error is detected.

In order to establish communication with the drum subsystem, the CONUS 24 must transmit two External Function words to the drum subsystem. These words contain the function code and the drum address where the operation is to begin. Twenty-two binary bits are required to specify the address of a unique word on the drum.

Before an EF transfer can take place the drum subsystem must present an Output Data Request signal to the computer. An Output Data Request will be present at all times during an input operation and whenever the subsystem is ready to receive a word from the computer during an output operation.

In the event of an abnormal condition on the MH-160 Magnetic Drum an external interrupt will be transmitted to the CONUS 24. Status words are placed on the input data lines whenever an External Interrupt is transmitted to the CONUS 24 indicating the cause of the External Interrupt.

A parity error interrupt will be transmitted to the computer immediately after the word in error is transferred. Parity is checked on a word basis, that is, a parity bit is generated and checked at the end of each word. A fault interrupt will be transmitted to the computer when any of the following conditions occur.

- a. The write circuitry is disabled.
- b. More than one recording head is selected.
- c. The recording heads are not lowered.

3.3 STANDARD COMMUNICATION SUBSYSTEM

The UNIVAC Standard Communication Subsystem comprises a Communication Multiplexer and a family of Communication Line Terminals. These Units may be provided in various configurations to satisfy the needs of particular application involved.

The Communication Multiplexer is a device which allows the connection of up to 64 simplex Communication Line Terminals to a single duplex input/output channel. While the Communication Multiplexer is available in modules

of 4, 8, 16, 32 and 64 Communication Line Terminal positions the true modularity of the Standard Communication Subsystem is exemplified by the family of Communication Line Terminals. Figure 3-1 illustrates the major elements of this family and their functional operation.

The UNIVAC Standard Communication Subsystem operates in a manner much like any other UNIVAC peripheral subsystem. When adapted to the CONUS 24 input/output channel, it controls the transfer of data between the processor and a broad range of remote input/output devices.

3.3.1 CONUS 24 INTERFACE

The transfer of data between the processor and the Standard Communication Subsystem takes place through input data leads connected to the input channel, and output data leads connected to the output channel. In addition to the data leads, there are several control leads which are used to control the flow of data.

1. Output Data Leads

There are ten output data leads. They originate at the processor output channel and they terminate at the output CLT. The External Function lead is monitored by the CLTs to distinguish between Function Words and data characters. If the External Function lead is active, the character on the output data leads is interpreted as a Function Word; if it is not active, the character is interpreted as data. Only the data characters are transferred to the transmission facilities.

2. External Function

This lead is activated by the CONUS 24 when the character on the output data leads is a Function Word rather than data.

3. Input Acknowledge

This lead is activated by the CONUS 24 upon completion of an input data transfer.

4. Output Acknowledge

This lead is activated by the CONUS 24 upon completion of an output data transfer.

5. Externally Specified Index Leads

There are 16 Externally Specified Index leads. Six of these leads

originate at the CLT positions of the Communication Multiplexer, while the remaining nine leads originate at a plugboard in the Communication Multiplexer. All 16 leads terminate at the processor input channel. These leads are active with each input data character and with each Output Data Request.

6. Input Data Leads

There are eight input data leads. They originate at the input CLT and they terminate at the processor input channel.

7. Output Data Request

This lead is activated by the Communication Multiplexer whenever it is signaled by a CLT that the CLT is ready to receive another data character from the CONUS 24.

8. Input Data Request

This lead is activated by the Communication Multiplexer whenever an input CLT has a data character ready to transfer to the CONUS 24.

9. Externally Specified Index Line

This line is active when operating in the ESI mode.

3.3.2. INPUT DATA TRANSFERS

An input data transfer will generally be accomplished in the following manner:

1. The input CLT receives a complete data character from the communication line.
2. CLTs with queuing registers transfer the data character to the queuing register and are ready to receive the next data character from the communication line.
3. The CLT signals the Communication Multiplexer that it has a complete data character ready to transfer to the processor.
4. When the Communication Multiplexer priority circuitry determines that it is ready to transfer the data character, it connects to the processor input channel the eight input data leads, the six Externally Specified Index leads which originate at the CLT, and the ten Externally Specified Index leads which originate at the Communication Multiplexer. It simultaneously activates the Input Data Request lead to the processor.

5. When the processor has accepted and stored the data character, it will activate the Input Acknowledge lead.
6. Receipt of the Input Acknowledge signal will cause the Communication Multiplexer to release its Input Data Request. It will also disconnect the Input Data leads and Externally Specified Index leads from the processor input channel. The Communication Multiplexer is then free to service another Communication Line Terminal.

This cycle will be repeated for each input CLT when it receives a complete data character from its associated communication line.

3.3.3 OUTPUT DATA TRANSFERS

All data transfers must be initiated by a Communication Line Terminal; however, an output Communication Line Terminal may not initiate an output data transfer until the processor instructs it to do so. An output data transfer will generally be accomplished in the following way:

1. The processor activates its External Function lead and simultaneously sends a Function Word on the ten Output Data leads. The Function Word contains a CLT Identifier Code which selects the desired CLT, as well as a Function Code which signals the CLT that the processor has a message ready to send.
2. The CLT, recognizing the Function Code, checks its associated communications facilities to be sure they are ready for transmission.
3. Having determined transmission ability, the CLT signals the Communication Multiplexer that it is ready to receive a data character.
4. When the Communication Multiplexer priority circuitry determines that it is able to service the CLT, it connects the six Externally Specified Index leads which originate at the CLT and the ten Externally Specified Index leads which originate at the Communication Multiplexer to the processor input channel and simultaneously activates the Output Data Request lead.
5. When the processor has recognized the Output Data Request signal and has located the proper character for the CLT as defined by the Externally Specified Index Address on the input channel, it will place the character on the output Data leads and activate the Output Acknowledge lead.
6. Recognizing the Output Acknowledge signal, the CLT will accept and store the character from the Output Data leads in its storage register. The Output Acknowledge signal will also cause the

Communication Multiplexer to release its Output Data Request and disconnect the Externally Specified Index leads from the processor input channel. The Communication Multiplexer is now free to service another Communication Line Terminal.

7. When the CLT which just effected the output data transfer has moved the character out of the register in which it was originally stored, either by transmitting it to the communication facilities or by moving it from a queuing register to a disassembly register, depending on the type of CLT, it will again signal the Communication Multiplexer that it is ready to transmit another character.
8. As the last character in a transmission is transferred from the processor to the CLT, it is accompanied by a programmed End of Transmission indication as well as by the normal Output Acknowledge signal. The End of Transmission indication will cause the CLT to stop requesting data characters until the processor sends another Function Word.

3.4 UNISERVO VIC MAGNETIC TAPE UNITS

For those functional applications in which intra-concentrator switching is to be performed, the Reference and Journal Storage entries must be retained for permanent records for all intra-concentrator messages. It is recommended that these files, initially recorded on the MH-160 Magnetic Drum, be periodically transferred and written on the UNISERVO Magnetic Tape.

The UNISERVO Magnetic Tape Unit provides the capability of reading and writing IBM compatible tapes at densities of 200, 556, and 800 characters per inch (CPI) in the IBM NRZ1 fashion. This format is used directly by CONUS 24 System; eliminating conversion on any other equipment.

One or two magnetic tape units (dual unit) may be connected to the system. It is possible to use a UNIVAC 1004 III compatible tape on one tape unit while the IBM compatible tape is in use on the other tape unit; for example, to read or write BCD on unit No. 1 and read or write 1004 internal code or another six level code on unit No. 2.

Data checking includes character parity (odd or even at programmer's option), longitudinal parity, and a read after write check.

UNISERVO Magnetic Tape may be used for permanent storage of large files and recording intermediate computation of data such as Reference and Journal entries.

A single UNISERVO Magnetic Tape Unit accepts a 2400 foot reel of plastic

tape with data recorded (or to be recorded) at a density of 200, 556, or 800 characters per inch.

One 2400 foot reel of magnetic tape weighs 45 ounces, is 10 1/2 inches in diameter, and will record data that would fill 150,000 to 160,000 80 column cards assuming a 10 card block length at 800 ppi.

The magnetic tape units perform reading and writing of data as directed by the CONUS 24 Program.

The UNISERVO Magnetic Tape Subsystem is completely compatible with the IBM Non Return to Zero mode of recording used by a number of business, industry, and government offices for data handling. Tapes may be written or read by unrelated data processing equipment (IBM, DCD, Honeywell, etc.) in the binary coded decimal/binary, non-return-to-zero format. It is possible to use a UNIVAC 1004 III tape on one tape unit while using an IBM compatible tape on the other tape unit.

When a read error, write error, or bad spot occurs on the tape, a signal is available for program recovery.

Data is protected by the removal of the write ring. The Tape Unit control panel warns operator of write ring insertion.

Any areas in storage may be designated as input or output areas when reading or writing magnetic tapes. Such areas are limited in size only by the capacity of storage. Tape blocks need not be read in their entirety: through the use of Data Ignore, they may be read in segments. This makes possible the reading of blocks in convenient units (a 600 character block could be read in segments of 300 characters), and the reading of blocks larger than storage (a 1500 character block could be read in three segments of 500 characters each).

The system is provided with a single tape unit. The dual tape unit can be supplied as an option in place of the single unit.

The magnetic tape unit is 72 1/2 inches high by 27 inches wide, by 31 1/2 inches, and weighs approximately 470 pounds. A dual unit will increase the width by 25 inches, and the weight by 450 pounds. Table 3-3 presents a summary of the UNISERVO Magnetic Tape Unit characteristics.

TABLE 3-3

UNISERVO VIC CHARACTERISTICS

TAPE	Mylar* tape in reels up to 2400'.	200 CPI	8,540 chars. per sec.
DATA FORMAT	Variable blocks of 6 bit characters. Interblock gap of 3/4 inches.	556 CPI	23,741 chars. per sec.
PROGRAMMED OPERATIONS	Read forward, write forward, backspace one block, data ignore, erase before write, transport select, and rewind.	800 CPI	34,160 chars. per sec.
TAPE SPEEDS	Read/Write Speed 42.7 inches per sec. Rewind Speed Less than 3 minutes.	DATA CHECKING	Character parity, longitudinal parity, read after write.
START/STOP TIMES	Read Start 9.5 ms. Read Start after Backspace 12.0 ms. Read Stop 10.5 ms. Write Start 8.2 ms. Write Check 7.0 ms. Write Stop 9.0 ms. Backspace Start 12.0 ms. Backspace Stop 10.5 ms.	I/O AREA	Any area of storage designated by programmer.
		DATA PROTECTION	Write ring must be inserted before tape unit will accept data. Tape unit control panel warns operator of insertion of write ring.
		SIMULTANEITY	Tape reading or writing and card or paper tape punching may occur at the same time.
		MAXIMUM NUMBER OF UNITS	One or two units per system (i.e.: one single or one dual unit per system).

* Trademark of the DuPont Company

Section 4

Programming

The programming for the proposed Message Concentrator is based on UNIVAC's past experience in computer communication systems. The focal point of the program organization is the Real-Time Executive System which controls the actual operational programs such as the Communication Input Subroutine, Intransit Subroutine, Reference Subroutine, Journal Subroutine, Communication Output Subroutine.

This section will discuss each of these operational programs as well as the Assembly provided for the UNIVAC CONUS 24 communication processor.

4.1 EXEC

The Real-time Executive System controls, sequences, and provides for the most efficient allocation use of facilities for the program operating in the UNIVAC CONUS 24 System. EXEC provides a number of basic subroutines which assist in matters of: console control, rerun, the loading of programs, input/output control for the various subsystems.

4.1.1 MAJOR FUNCTIONS

These components comprise the major functions of EXEC.

A. Selection and Loading

Programs are presented for selection either by operator specification or on a pre-planned Master Instruction Tape and EXEC will select and load them on the basis of parameters which were incorporated in the Master Instruction Tape at the time of its creation. The operator may select programs on demand and may also inhibit the operation of a program.

B. Console Control

Provision is made for a running program to inform the operator of conditions that may exist during operation, as the completion of a load, or the malfunction of a peripheral unit. Provision is also made for the operator to effect the operation of a program by input messages. These requests are made through the intercept position.

C. Switcher

The switcher is a routine which by means of a scan of "outstanding work" indicators, (counters) insures that the proper routines come into control in a sequence which is keyed both to a present priority sequence and to conventional "first in - first out" handling. "Outstanding Work" consists of:

1. Interrupts

Communications input, communications output, communications external, standard in and output interrupts, which have been noted in counters but not handled.

2. Suspended Routines Awaiting Return of Control

Only one routine in each of the real-time, batch and computational modes may be suspended at one time.

3. Places to Go

Most often return (done) addresses placed in one of the four place to go stacks (according to 4 program levels - (a) EXEC - critical, (b) real-time, (c) batch, (d) computational), by some I/O handler. This would indicate a satisfactory completion of an I/O request, a place to go can, among other things, also be the starting address of some routine, which has been called on by program or console request.

D. Communication and Non-Communication Interrupt Answering Service

The interrupted routine is checked if its level is critical (EXEC interrupted). If the mode is critical the interrupt is marked in a counter in the Switcher (see C, Switcher 1 Interrupt) and control is given back to the interrupted routine. If the interrupted routine is not critical this routine is suspended according to level (see C, Switcher 2 Suspended Routines) and EXEC gives control to the specific handler interrupt service.

E. Handler Interrupt Services

Provide a check on error conditions (status word) and link to error handling if necessary. Normally the done address is scheduled as a place to go stack of appropriate level. The routine goes then to the handling of the next I/O request.

F. Master Handler

Performs functions common to all worker program I/O requests such as queueing, of I/O requests, IRL (immediate return line) - and done processing. It transfers to specific handler hardware specific analysis (function check - error recovery - buffer control word check).

G. Place To Go

Accepts addresses of locations to which control is to be transferred after higher priority tasks have been taken care of. The addresses are scheduled in the appropriate place to go stacks.

4.1.2 EXEC SERVICES

An operating program is provided with several loading and allocation functions.

- A. The EXEC loading mechanism provides for loading of following programs as called by the console or programs.
- B. Rerun dumps and debugging functions such as Print Storage and Inspect Storage are accomplished by EXEC.
- C. A program that has reached its logical termination point will release all its facilities by a separate utility request.

Facilities Required:

EXEC comprises its basic control routines and tables and a selected number of input/output handler routines. The selection of the input/output handlers is based upon the user's configuration and the memory requirements will vary depending upon the selection.

EXEC will operate with or without a Master Instruction Tape. If a Master Instruction Tape is used then the system must be provided with at least a card subsystem or a paper tape subsystem.

4.2 COMMUNICATION INPUT SUBROUTINE

This subroutine is activated by the Executive Control Routine to process an incoming message. This activation is the result of an input buffer being filled. The Communication Input Subroutine has three major sections depending on the status or type of incoming data. These sections are Heading analysis and Text analysis. Each input line has a status word which is established by program and which denotes the current type of data being received, i.e., Header, Text, or EOM. The Communication Input Subroutine will first test this status word to ascertain the point in the subroutine that the processing should begin.

4.2.1 HEADER ANALYSIS

This portion of the Communication Input Subroutine will examine the data characters in the buffer for correct heading format, parity and validity of routine indicator. If the SOM character or sequence is detected, an entry is made in the status word to activate the Journal Subroutine for an SOM entry.

If a routing indicator is found which is a group routing indicator, that is, a single routing indicator which is common to a number of addressees, the necessary conversion to individual routing indicators is made. The routing indicators are then analyzed to determine if the message is deliverable locally or via AUTODIN or both. If the message is to be delivered locally and was not received from AUTODIN, the appropriate entry is made in the status word to activate the Reference Subroutine. The data characters are then packed 3 per word into the packing buffer. The packing buffer is then tested to determine if it is filled, that is, it contains 80 data characters. An entry is made in the status word if this packing buffer is complete so that the In-transit Subroutine will be activated.

The Subroutine will also test for an end of line block condition for Mode I input lines. If this condition is present, the appropriate acknowledge character is sent to the originator. The end of heading is also searched for, and if found, the status word is modified to indicate that the next time the Communication Input Subroutine is activated, analysis should begin with text.

Control is then returned to the Executive Control Routine. Upon regaining control the Executive Control Subroutine will examine the status word and determine the next subroutine to be activated.

4.2.2. TEXT ANALYSIS

This portion of the Communication Input Subroutine will check parity for the data characters in the input buffer, and pack the data characters into the packing buffer. If the packing buffer is filled, the appropriate entry is made in the associated status word to activate the In-transit Subroutine. If on a Mode 1 channel and an end of line block is detected, the horizontal parity check is made and the appropriate response is sent to the originator.

This portion of the Communication Input Subroutine will also check for the end of message (EOM). If an EOM is detected, the data characters will be packed in the packing buffer and even if the packing buffer is not complete, the associated status word will be modified to activate the In-transit Subroutine. The status word is further modified, in this case, to activate the Journal Subroutine for an EOM Journal entry. The appropriate acknowledge will then be sent to the originator.

The status word is also modified to indicate that the next time the Communication Input Subroutine is activated, analysis should begin looking for the message header. Control is then returned to the Executive Control Routine.

4.3 IN-TRANSIT SUBROUTINE

Upon activation the In-transit Subroutine will access completed input packing buffer and prepare it for transfer to the In-transit Storage. The available areas on the In-transit Storage are maintained by the In-transit Subroutine on a Drum Availability Table.

If the data block is a start of Message block, the next available drum location is accessed for the storage of this block. A second available location is also found and reserved. The address of this second location is added to the data block and the block is stored on the drum. When the next data block of this message is available for In-transit Storage, the data block is stored at this previously reserved location and a third location is reserved. The address of this third location is added to the end of the second data block as it is stored on the In-transit Storage. This technique is known as Threading and is repeated for every data block of each input message except for the last data block. The last data block which contains the EOM does not have a drum location address added to it when it is stored.

When the EOM is stored on the In-transit Storage, the drum address of the first data block of this message is placed in the appropriate output channel Queue Tables.

As the data blocks are accessed from the In-transit Storage by the In-transit Subroutine for output transmission, the address of the next data block of a particular message is found appended to the current data block. Access of data blocks from the In-transit Storage is performed only upon request of the Communication Output Subroutine through the Executive Control Routine.

After a data block has been stored on the drum or read from the drum and made available to the Communication Output Subroutine, control is returned to the Executive Control Routine.

4.4 REFERENCE SUBROUTINE

The Reference Subroutine is activated through the Executive Control Routine when a message is received from a local tributary and destined for another local tributary. The individual data blocks of these messages are recorded on the Reference Storage at essentially the same time that they are stored on the In-transit Storage.

Normally, the Reference Subroutine is a unidirectional function, that is, it primarily records data. However, upon command from the Message Distribution Center's console through the Executive Control Routine, the Reference Subroutine will recover from Reference Storage any desired message stored.

The Reference Subroutine also checks the utilization of the storage capacity and notifies operating personnel when a predetermined point or threshold is reached.

After a data block is recorded on Reference Storage, the control is returned to the Executive Control Routine.

4.5 JOURNAL SUBROUTINE

The Journal Subroutine is activated when a Journal Storage entry is to be made. The Journal entries are made at the receipt of SOM, receipt of EOM, transmit of SOM and transmit of EOM for each message passing through the Message Distribution Center. The Journal entry will also contain information indicating where the Reference Storage record is maintained, locally or at the AUTODIN Center. After the Journal entry is made control is returned to the Executive Control Routine.

4.6 COMMUNICATION OUTPUT SUBROUTINE

The Communication Output Subroutine is activated by the Executive Control Routine when an output line buffer empties and causes an internal interrupt or if the output line is idle and the In-transit Subroutine loads a drum address into one of the Queue Tables associated with this output line. Upon activation the Communication Output Subroutine accesses the next 6 characters from the unpacking buffer, unpacks these characters and performs any code or format conversion. If these 6 characters are the last contained in the unpacking buffer, the Communication Output Subroutine modifies the status word which is associated with this output line so that upon return of control to the Executive Subroutine, the In-transit Subroutine will be activated to access the next data block of this message from the drum.

If the 6 characters processed from the unpacking buffer contain the EOM, the Communication Output Subroutine will request the next message's starting drum address from the Queue Table, according to relative precedences and notify the In-transit Subroutine through the Executive Control Routine.

After the 6 characters have been processed and prepared for output transmission, control is returned to the Executive Control Routine.

4.7 ART ASSEMBLY SYSTEM

The ART Assembly System for the UNIVAC Concentrator provides programming assistance through use of its symbolic shorthand. This simplified system converts a source program written with symbolic addressing into an object program with absolute or relocatable addressing. ART produces the assembled object program on punched cards or magnetic tape suitable for loading into the UNIVAC CONUS 24 via the ART Utility Package.

ART is a two-pass assembler designed for an equipment configuration of one UNIVAC CONUS 24 with 8192 (decimal) Words of core memory and acceptable input/output equipment for example, one paper tape reader and punch, a 1004 card processor, read and print and Uniservo magnetic tape units. The assembler accepts a source program expressed symbolically, absolutely, or in combination thereof and converts it into an ordered set of machine instructions suitable for loading. The term two-pass is defined as meaning the source program must be loaded into the computer twice. The first such loading, constituting pass one, assimilates and stores, information needed for pass two. At the completion of pass one the source program must again be loaded and the desired output selected. Using the information accumulated during pass one, pass two reads, assembles, and punches on paper tape, or lists on the 1004 each source program instruction, statement by statement. This second loading constitutes pass two. Subsequent outputs are achieved by repeating (reloading) pass two.

The Assembly System has the following features.

1. Source code format -

Built around papertape or punched card, the line of code consists of a label (one to six alphanumeric characters), op code (up to three characters), operand (to twenty characters) and comments fields in fixed card positions.

2. Source code field contents -

- a. Operands may be of the form -
 DDDDDD an absolute address or quantity
 TAG
 TAG †
 \$ † where \$ signifies the current line counter setting.
- b. Constant may be positive or negative, decimal or octal.
- c. Basic Assembler directives -
 RES SET EVN END EQU CLT

3. Object code -

will be punched as a by product in absolute or relative form.

4. A side by side listing is available in both versions.

SUMMARY OF FACILITY REQUIREMENTS

	<u>Input</u>	<u>Output</u>	<u>Words of Core</u>
ART	Card Papertape	Papertape Magnetic tape Print	8192

4.8 CONUS 24 SUBROUTINES

As an illustration of the programming simplicity of the UNIVAC CONUS 24 the following example of operational subroutines are presented. Also included are the layouts of the Communication Line Terminal Control Packets. These Control Packets are used to maintain the current status of each Communication Line Terminal and are analyzed by the subroutines in order to ascertain the appropriate point of entry so that the processing of data may be continued.

4.8.1 BLOCK PARITY SUBROUTINE

I. Input Conditions.

1. The base address of the packed buffer is in the arithmetic register.
2. The buffer is 28 words long.

II. Exist Conditions.

1. The result is placed in the low order eight bits of the arithmetic register

III. Memory Requirements.

The routine occupies 43 storage locations.

IV. Timing.

442.5 micro seconds per block.

4.8.2 CHARACTER PARITY CHECK, CONTROL CODE CHECK, INVALID CHARACTER CHECK

I. Input Conditions.

1. The address of the first character to be checked is in arithmetic register.
2. The buffer is 6 characters long.

II. Exit Conditions.

1. Error switches will be set if appropriate.
2. Receiver control switches will be set if appropriate, and the characters dropped from the data.
3. Invalid data characters will be replaced with asterisks.

III. Memory Requirements.

The routine occupies

13 instruction locations
265 table locations
<u>10</u> jump table locations
279 core store cells.

IV. Timing.

610.0 micro seconds per 6 character buffer

4.8.3 INPUT BUFFER PACKING

I. Input Requirements.

1. Input CLT packet set up as required.
2. Address of input CLT packet in the arithmetic register.

II. Exit Conditions.

1. The input buffer is packet 3 characters per word.
2. Partial words due to drop outs in the input message are retained for the next buffer to fill.
3. The input CLT packet is adjusted as necessary.

III. Memory Requirements.

64 storage locations are used by the routine.

IV. Timing.

510.0 micro seconds per 6 character input buffer.

Note that timing will vary due to current input buffer contents and length.

UNIVAC CONUS 24 Assembly System

Application Message Distribution Program Block Parity Page 1

Line	Op	Y	I	A	Remarks
AAA	0	0			Entry Line
	SIA	DOG			1 Sets Buffer Base
	LDA	DOG	X		Loads First Word of Block
	OR	DOG	X		Forms block parity word 2
	OR	DOG	X		Word 3
	OR	DOG	X		Word 4
	OR	DOG	X		Word 5
	OR	DOG	X		Word 6
	OR	DOG	X		Word 7
	OR	DOG	X		Word 8
	OR	DOG	X		Word 9
	OR	DOG	X		Word 10
	OR	DOG	X		Word 11
	OR	DOG	X		Word 12
	OR	DOG	X		Word 13
	OR	DOG	X		Word 14
	OR	DOG	X		Word 15

Line	Op	Y	I	A	Remarks
	OR	DOG	X		Word 16
	OR	DOG	X		Word 17
	OR	DOG	X		Word 18
	OR	DOG	X		Word 19
	OR	DOG	X		Word 20
	OR	DOG	X		Word 21
	OR	DOG	X		Word 22
	OR	DOG	X		Word 23
	OR	DOG	X		Word 24
	OR	DOG	X		Word 25
	OR	DOG	X		Word 26
	OR	DOG	X		Word 27
	OR	DOG	X		Word 28
	SYI	CAT			Save first character of parity word.
	SYL	1			Shift the A Register 8 Bits
	SYI	CAT1			Save 2nd character
	SYL	1			Shift the A Register 8 Bits

Line	Op	Y	I	A	Remarks
	SY1	CAT2			Save 3rd character
	LDA	CAT			First character of block parity to A
	OR	CAT1			
	OR	CAT2			Block parity is now in the A Register
	JP	AAA	X		Exit
DOG	0	0		X	Advance bit is set
CAT	0	0			Temporary Stores
CAT1	0	0			
CAT2	0	0			

Line	Op	Y	I	A	Remarks
AAA	0	0			ENTRY LINE
	STA	DOG			SETS BUFFER BASE
	LDA	DOG	X		PICK UP CHARACTER
	SY1	CAT			SAVE CHARACTER
	ADD	BOY			DEVELOPE TABLE LOCATION
	STV	GIRL			SAVE
	LY1	1	X		PICK UP TABLE CHARACTER
	CY1	CAT			COMPARE WITH DATA CHARACTER
	JPZ	ABC			PARITY IS CORRECT
	JP	ERR			JP TO SET ER FLAG
ABC	LY2	GIRL	X		PICK UP INDICATOR
	ADD	WIFE			DEVELOPE BRANCH
	JP	1	X		BRANCH ON TYPE
DOG	0	0		X	TEMPORARY STORAGE FOR BUFFER BASE
CAT	0	0			STORE FOR CHARACTER
BOY		FLDTAB			TABLE BASE ADDRESS
GIRL	0	0			STORE FOR TABLE LOCATION

UNIVAC CONUS 24 Assembly System

Application Message distribution

Program Character Parity

Page 2

Line	Op	Y	I	A	Remarks
WIFE		JPTTAB			JUMP TABLE BASE FOR TYPE OF CHARACTER
JPTTAB		DTRTN			ENTRANCE TO DATA CHARACTER ROUTINE
		ILLRTN			INVALID CHARACTER
		SOMRTN			START OF MESSAGE
		SOBRTN			START OF LINE BLOCK
		EOMRTN			END OF MESSAGE
		EOBRTN			END OF LINE BLOCK
		AK1RTN			ACKNOWLEDGE 1
		AK2RTN			ACKNOWLEDGE 2
		RTMRTN			REJECT MESSAGE
		DIMRTN			DISCARD MESSAGE
		WBTRTN			WAIT BEFORE XMIT
		ERRRTN			ERROR ROUTINE

Line	Op	Y	I	A	Remarks
AAA	0				Entry line
	STA	DOG			SAVE CLT BASE ADDRESS
	LDA	DOG	X		PICK UP INPUT BUFFER BASE
	STA	BUFF			SAVE
	LDA	DOG	X		PICK UP CURRENT PACK BUFFER BASE
	STA	PACK			SAVE
	LDA	DOG	X		PICK UP CURRENT PACK WORD ADDRESS
	STA	PW			SAVE
	LY3	DOG	X		PICK UP CURRENT Y LOCATION
	STA	PY		SAVE	SAVE
	LDA	DOG	X		PICK UP CHARACTER COUNT ADDRESS
	STA	CC			SAVE
PY	LDC	0			CURRENT Y CONSTANT 0 is Y3, 1 is Y2, 2 is Y1
	ADD	YTAB			DEVELOPE JUMP ADDRESS
	JP	1	X		BRANCH
YTAB		Y3			
		Y2			

Line	Op	Y	I	A	Remarks
Y3	LDA	Y3 BUFF	X		PICK UP CHARACTER
	CY1	INV			CHECK FOR DROP OUT
	JPZ	Y31			DROP OUT
	SY3	PW	X		PACK INTO Y3
	DEC	CC	X		DECREMENT CHARACTER COUNT
	JPZ	Y32			COUNT EXHAUSTED
	JP	Y2			
	DEC	CC	X		DECREMENT CHARACTER COUNT
	JPZ	U32			COUNT EXHAUSTED
	JP	Y3			GET NEXT FOR Y3
Y32	LDC	1			SET Y LOC FOR NEXT BUFFER
	DEC	DOG			COUNT CLT BASE DOWN
Y33	DEC	DOG			
	SY3	DOG	X		SAVE CURRENT Y
	JP	AA	X		EXIT
Y2	LDA	BUFF	X		PICK UP CHARACTER

Application Message Distribution

Line	Op	Y	I	A	Remarks
	CY1	INV			
	JPZ	Y21			
	SY2	PW	X		
	DEC	CC	X		
	JPZ	Y22			
	JP	Y1			
Y21	DEC	CC	X		
	JPZ	Y22			
	JP	Y2			
Y22	LDC	2			SET NEXT Y LOCATION
	JP	Y33			
Y1	LDA	BUFF	X		PICK UP CHARACTER
	CY1	INV			
	JPZ	Y11			
	SY1	PW	X		PACK LAST CHARACTER
	LDA	PW	X		PICK UP PACKED WORD
	STV	PACK	X		STORE PACKED WORD IN BUFFER

UNIVAC CONUS 24 Assembly System

Program Buffer Packing

Application Message Distribution

Line	Op	Y	I	A	Remarks
	DEC	CC	X		DECREMENT CHARACTER COUNT
	JPZ	Y12			COUNT EXHAUSTED
	JP	Y3			GET NEXT
Y12	LDC	0			SET NEXT LOCATION
	JP	Y33			
Y11	DEC	CC	X		DECREMENT CHARACTER COUNT FOR THROW A WAY.
	JPZ	Y12			COUNT EXHAUSTED
	JP	Y1			GET NEXT
DOG	0	0		X	CLT BASE STORE
BUFF	0	0		X	CHARACTER BASE STORE
PACK	0	0	X		ADDRESS OF PACK BUFFER
PW	0	0	X		ADDRESS OF PACK WORD
CC	0	0	X		ADDRESS OF CHARACTER COUNT

INPUT CLT PACKET

	23	22	21	20	19	18	17	16	15	14	13	12	11	10	9	8	7	6	5	4	3	2	1	0	
0	Primary input buffer address																								
1	Secondary input buffer address																								
2	Current input buffer address																								*
3	Packing buffer address																								
4	Secondary packing buffer address																								
5	Current packing word address																								*
6	Current packing word																								
7	Analysis subroutine currently in control																								
8	Time of SOM																								
9	Internal job number																								
10	Character count of input																								
11	Current pack Y location								Current in buffer flag								Current pack buffer flag								
12	Current drum thread address																								

AN EXAMPLE OF AN INPUT CLT CONTROL PACKET

* Indicates that the advance bit will be set

OUTPUT CLT PACKET

23	22	21	20	19	18	17	16	15	14	13	12	11	10	9	8	7	6	5	4	3	2	1	0
Primary output buffer address																							
Secondary output buffer address																							
Current output buffer address																							
Primary unpacking buffer address																							
Secondary unpacking buffer address																							
Current unpacking word address																							
Current priority								Current out buffer flag								Current unpack buffer flag							
Current drum thread beginning address																							
Interrupted priority 2 drum thread beginning address																							
Interrupted priority 3 drum thread beginning address																							
Interrupted priority 4 drum thread beginning address																							

AN EXAMPLE OF AN OUTPUT CLT CONTROL PACKET

* Indicates that the advance bit will be set

BLOCK PARITY CHECK OR GENERATE

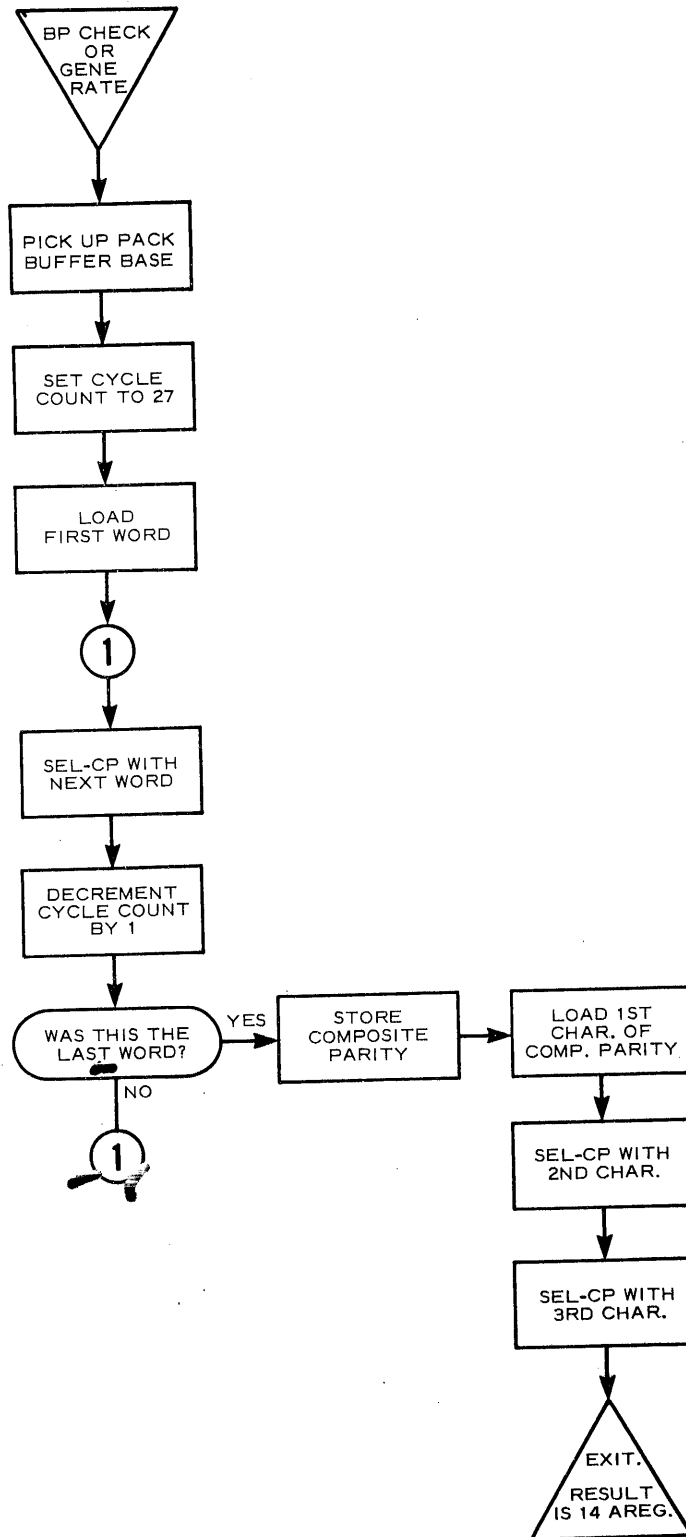

PACK INPUT BUFFER

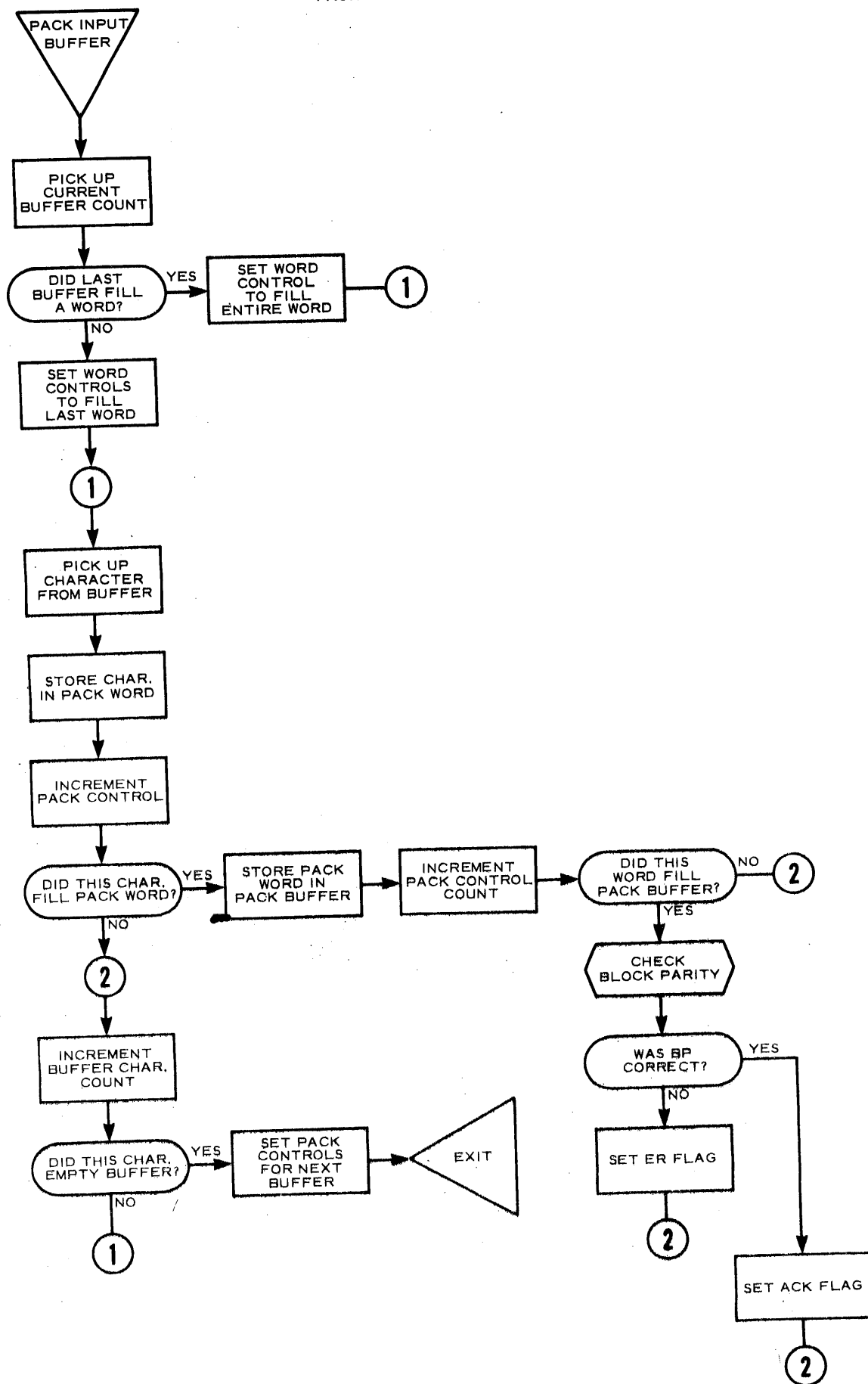

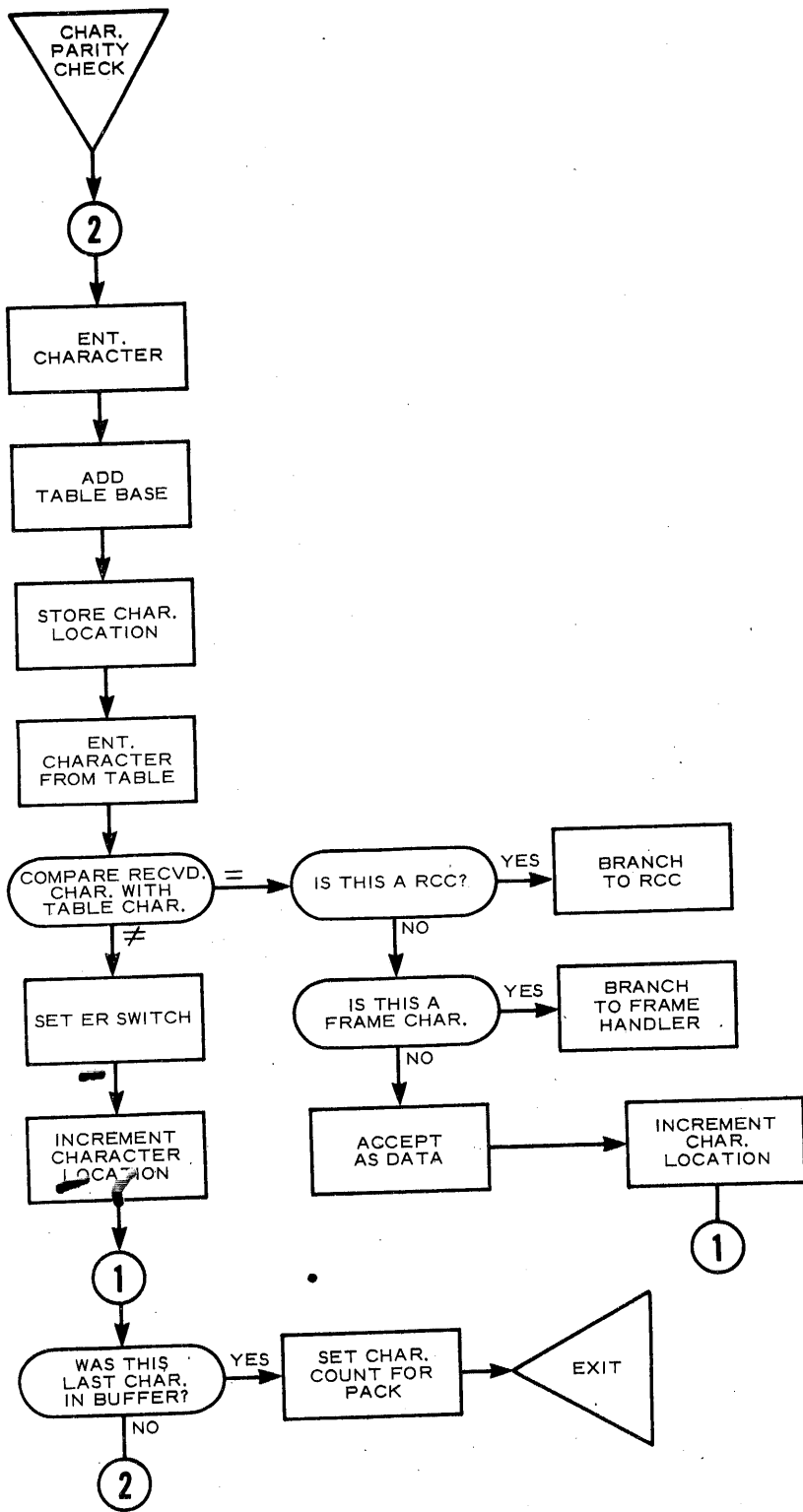

SECTION 5

5.1 System Operation

The proposed UNIVAC Message Concentrator will function efficiently and economically in both functional applications. Since the internal system operation of the Message Concentration is essentially the same complete analysis of both functional applications would be unnecessarily redundant. The more complex function application with intrac concentrator switching will be analyzed in depth. Establishing the proposed Message Concentrator capability for processing these more complex functions will also establish its capability for easily performing the simpler functions required by the functional application without intra-concentrator switching.

The analysis of a message concentrator must include four aspects of operation in order to ascertain the acceptability of the proposed system. These aspects are circuit capacity/utilization for an average and peak time sample, computer Input/Output timing for the peak minute, program timing for the peak minute and the internal storage utilization. These items have been evaluated for the proposed Message Concentrator with intra-concentrator switching and are presented with a tabulation of the resulting statistics. It is also assumed that the UNISERVO VIC Magnetic Tape Units are employed, thereby, increasing the complexity of the problem.

The operational assumptions for this model are as follows:

- 1) Communication Circuit Configuration
 - 20 - 150 baud full duplex Mode V or Mode 1 tributaries
 - 4 - 1200 baud full duplex Mode 1, block-by-block, tributaries
 - 2 - 2400 baud full duplex AUTODIN trunks, Mode 1, continuous mode
- 2) All circuits are 60% utilized
- 3) Messages received from AUTODIN are evenly distributed as to tributary circuit speed.

- 4) 20% of the messages received from the tributaries are also destined for the tributaries, therefore intra-concentrator switching.
- 5) Address multiplicity is 1.75 addresses per message.

5.1.1 Communication Circuit Capacity/Utilization

The first aspect to determine is if the system configuration is properly balanced with respect to communication circuit capacity. It would be poor system engineering if the total average input data volume exceeded the output data volume capacity. This would mean that even during an average period of utilization constantly grow queues were being developed so that the system would soon saturate. Table 5-1 presents a tabulation of data volume capacity for the average minute. This analysis is divided into a concentration function to AUTODIN and a distribution function from AUTODIN.

TABLE 5-1
Communication Circuit Capacity

A. Average Minute - Concentration Function

Input to Concentration

From Mode I TRIB at 48%	17,280.00 Characters
at 84 char/block	205.71 Blocks
at 25 blocks/message	8.23 Messages
From Mode V TRIB at 48%	8,640.00 Characters
at 80 char/block	108.00 Blocks
at 25 blocks/message	4.32 Messages

Outputs from Concentration

Messages from Mode I TRIB	8.23 Messages
Messages from Mode V TRIB	<u>4.23 Messages</u>
Total Messages	12.55
at 25 blocks/message	313.71 Blocks
at 84 char/block	26,351.64 Characters

B. Average Minute - Distribution Functions

Input to Distribution

From Trunk at 60%	21,600.00 Characters
at 84 char/block	257.14 Blocks
at 25 blocks/message	10.28 Messages

From Mode I TRIB at 12%	4,320.00 Characters
at 84 char/block	51.43 Blocks
at 25 blocks/message	2.06 Messages
 From Mode B TRIB at 12%	 2,160.00 Characters
at 80 char/block	27.00 Blocks
at 25 blocks/message	1.08 Messages

Average Minute

Outputs from Distribution

From Trunks at 60%	10.28 Messages
From Mode I at 12%	2.06 Messages
From Mode V at 12%	1.08 Messages
Total Messages for Distribution	13.32
Total Addresses for Distribution	
at 1.75 addresses/message	23.31 Messages

C. Distribution (See assumption 3 in Section 4.1)Messages for Distribution

Mode I TRIB at 67%	15.62
Mode V TRIB at 33%	7.69

Blocks for Distribution

Mode I TRIB at 25%	390.50
Mode V TRIB at 25%	192.25

Characters for Distribution

Mode I TRIB at 84/block	32,802.00
Mode V TRIB at 80/block	15,380.00

D. Circuit UtilizationD.1 Input Trunk from Autodin (2 Trunks)

Messages for Distribution	10.28
Blocks for Distribution	257.14
Characters for Distribution	21,600.00
Acknowledge Characters from Concentrator at 2 per block	627.42
 Total Input Capacity of Trunks	 36,000.00 Characters
Total Input from Autodin	22,227.42 Characters
Spare Input from Autodin	13,772.58 Characters

D.2 Output Trunk to Autodin (2 Trunks)

Messages from Concentration	12.55	
Blocks from Concentration	313.71	
Characters from Concentration	26,351.64	
Acknowledge Characters from Distribution at 2 per block	514.28	
Total Output Capacity of Trunks	36,000.00	Characters
Total Output to Autodin	<u>26,865.92</u>	Characters
Spare Output to Autodin	9,134.08	Characters

D.3 Input Mode I from TRIB (4 Circuits)

Messages for Concentration	8.23	
Messages for Distribution	<u>2.06</u>	
Total Messages	10.29	
Blocks for Concentration	205.71	
Blocks for Distribution	<u>51.43</u>	
Total Blocks	257.14	
Characters for Concentration	17,280.00	
Characters for Distribution	<u>4,320.00</u>	
Total Characters	21,600.00	
Acknowledge character from Distribution at 2 per block	781.00	
Total Input Capacity of Circuits	36,000.00	Characters
Total Input Requirements	<u>22,381.00</u>	Characters
Spare Input from Mode I TRIBS	13,619.00	

D.4 Output Mode I to TRIB (4 Circuits)

Messages from Distribution	15.62	
Blocks from Distribution	390.50	
Characters from Distribution	32,802.00	
Acknowledge Characters from Concentration/Distribution at 2 per block	514.28	
Total Output Capacity of Circuit	36,000.00	Characters
Total Output Requirements	<u>33,316.28</u>	Characters
Spare Output to TRIB	2,683.72	Characters

D.5 Input Mode V from TRIB (20 Circuits)

Messages for Concentration	4.32	
Messages for Distribution	<u>1.08</u>	
Total Messages	5.40	

Blocks for Concentration	108.00	
Blocks for Distribution	<u>27.00</u>	
Total Blocks	135.00	
Characters for Concentration	8,640.00	
Characters for Distribution	<u>2,160.00</u>	
Total Characters	10,800.00	
Acknowledge Characters from Distribution at 2 per message	15.38	
Total Input Capacity of Circuits	18,000.00	Characters
Total Input Requirements	<u>10,813.38</u>	Characters
Spare Input from Mode V TRIBS	7,184.62	
<u>D.6 Output Mode V to TRIBS (20 Circuits)</u>		
Messages from Distribution	7.69	
Blocks from Distribution	192.25	
Characters from Distribution	15,380.00	
Acknowledge Characters from Concentration/Distribution at 2 per message	10.80	
Total Output Capacity of Circuits	18,000.00	Characters
Total Output Requirements	<u>15,390.80</u>	Characters
Spare Output to TRIB	2,609.20	Characters

The propose message concentrator configuration is capable of through putting the average traffic volume including the additional traffic created by the intra-concentrator switching function with the creation of internal queues. The next point of analysis is to perform the exercise for peak minute. It is expected that queues will be created and therefore the analysis must determine the rate at which the queue will grow and the capacity of the in-transit storage so that the maximum period of time that the peak can be tolerated will be defined.

Table 5-2 presents the same analysis as Table 5-1 for the peak minute.

Normal intransit storage requirements will be areas to contain one message coming into the message concentrator from each of the input lines and one message going out to each of the output lines. With an average message length of 2000 characters this area would consist of 104,000 characters. Since during the average period, output data volume capacity is greater than the input data volume, this figure will be mainly accurate, only being affected by multiple address messages, busy circuit conditions on

output and by messages of greater than the 2,000 character average.

During the peak minutes, however, we find input developing which is in excess of output capabilities. Referring to Table 5-2, the input from all sources would be 33,911.40 characters added to the in-transit storage queue each minute. Since approximately 3,000,000 characters on the MH-160 Magnetic Drum are to be reserved for intransit storage, the proposed Message Concentrator could easily process a sustained peak of up to 85 minutes before the program would have to revert to any abnormal procedures, such as, a WBT/REP sequence.

5 1.2 CONUS 24 Input/Output Timing

In Section 5.1.1 the feasibility of the communication circuit configuration was established as being realistic. The next aspect is to determine if the CONUS 24 can transfer the data characters across its Input/Output channels within the time required by the overall data flow and to determine the CONUS 24 memory utilization to perform these input/output transfers. It will require three memory cycles to effect a single word transfer. If the word contains only one character such as from the Standard Communication Subsystem the time to transfer each character is also three memory cycles or 7.5 microseconds. Table 5-3 presents a summary of this portion of the total analysis.

5.1.3 Program Timing

The next aspect to be ascertained is if the proposed computer's program can actually process all this data within the time frame allotted. Table 5-4 presents the program time for the peak minute which is the worst case. This analysis will show that even during the peak minute the program is able to keep ahead of the data traffic flow.

5.1.4 Storage Requirements

The last aspect to be analyzed is to determine if the propose Message Concentration has sufficient internal storage in its core memory. Table 5-5 presents a summation of this analysis.

Table 5-6 is a summary of storage requirements of a minor switching center. The main difference is in the number of memory locations used for executive and operating program storage.

TABLE 5-2

Communication Circuit Capacity

A. Peak Minute - Concentrator Function

Input to Concentration

From Mode I TRIB at 80%	28,129.44 Characters
at 84 char/block	334.93 Blocks
at 25 blocks/message	13.39 Messages
From Mode V TRIB at 80%	14,385.60 Characters
at 80 char/block	179.82 Blocks
at 25 blocks/message	7.19 Messages

Outputs from Concentration

Messages from Mode I TRIB	13.39
Messages from Mode V TRIB	<u>7.19</u>
Total Messages	20.58
at 25 blocks/messages	514.50 Blocks
at 84 char/block	43,218.00 Characters

B. Peak Minute - Distribution Function

Input to Distribution

From Trunk at 100%	35,162.80 Characters
at 84 char/block	418.63 Blocks
at 25 blocks/message	16.74 Messages
From Mode I, TRIB at 20%	7,033.36 Characters
at 84 char/block	83.47 Blocks
at 25 blocks/message	3.30 Messages
From Mode V TRIB at 20%	3,596.40 Characters
at 80 char/block	44.95 Blocks
at 25 blocks/message	1.80 Messages

Peak Minute

Outputs from Distribution

Messages	from Trunks	16.74
	from Mode I	3.30
	from Mode V	<u>1.80</u>
Total Messages		21.84
Total addresses for Distribution		
	at 1.75 addresses/message	38.22

C. Distribution - (see assumption 3 under Section 4.1)

Messages for Distribution		
	Mode I TRIB at 67%	25.61
	Mode V TRIB at 33%	12.61
Blocks for Distribution		
	Mode I TRIB at 25 blocks/message	640.25
	Mode V TRIB at 25 blocks/message	315.25
Characters for Distribution		
	Mode I TRIB at 84 char/block	53,781.00
	Mode V TRIB at 80 char/block	25,220.00

D. Circuit Utilization

D.1 Input Trunk from AUTODIN (2 trunks)

Messages for distribution	16.74
Blocks for distribution	418.63
Characters for distribution	35,162.80
Acknowledge characters from Concentration @ 2 per block	837.20
Total input capacity of trunks	36,000.00
Total input from AUTODIN	<u>36,000.00</u>
Spare input from AUTODIN	0.00

D.2 Output Trunk to AUTODIN (required)

Messages from Concentration	20.58
Blocks from Concentration	514.50
Characters from Concentration	43,218.00
Acknowledge Characters from Distribution @ 2 per block	837.20
Total output capacity of Trunks	36,000.00 Characters
Total output requirements	<u>44,055.20</u> Characters
Short Capacity to AUTODIN	8,055.20 Characters

D.3	<u>Input Mode I from TRIB</u>	(4 circuits)	
	Messages for Concentration		13.39
	Messages for Distribution		<u>3.30</u>
	Total Messages		16.69
	Blocks for Concentration		334.93
	Blocks for Distribution		<u>83.47</u>
	Total Blocks418.40
	Characters for Concentration		28,129.44
	Characters for Distribution		<u>7,033.36</u>
	Total Characters.35,162.80
	Acknowledge Characters from		
	Distribution at 2 per block		837.20
	Total input capacity of circuits		36,000.00 Characters
	Total input from circuits		<u>36,000.00</u> Characters
	Spare input from circuits		0.00 Characters
D.4	<u>Output Mode I to TRIB</u>	(4 circuits)	
	Messages from Distribution		25.61
	Blocks from Distribution		640.25
	Characters from Distribution		53,781.00
	Acknowledge Characters from		
	Concentration/Distribution at 2/block		837.20
	Total output capacity of circuits		36,000.00 Characters
	Total output requirements		<u>54,618.20</u> Characters
	Short capacity to circuits		18,618.20 Characters
D.5	<u>Input Mode V from TRIB</u>	(20 circuits)	
	Messages for Concentration		7.19
	Messages for Distribution		<u>1.80</u>
	Total Messages		8.99
	Blocks for Concentration		179.82
	Blocks for Distribution		<u>44.95</u>
	Total Blocks224.77
	Characters for Concentration		14,285.60
	Characters for Distribution		<u>3,596.40</u>
	Total Characters		17,982.00
	Acknowledge Characters from		
	Distribution at 2 per Message		18.00

Total input capacity of circuits	18,000.00	Characters
Total input requirements	<u>18,000.00</u>	Characters
Spare input from Mode V TRIB	0.00	Characters
D.6 <u>Output Mode V to TRIBS</u> (20 circuits)		
Messages from Distribution	12.61	
Blocks from Distribution	315.25	
Characters from Distribution	25,220.00	
Acknowledge Characters from Concentration/Distribution at 2/Message	18.00	
Total output capacity of circuits	18,000.00	Characters
Total output requirements	<u>25,238.00</u>	Characters
Short output to Mode V TRIB	7,238.00	Characters

TABLE 5-3
CONUS 24 Input/Output Transfer Timing

A. Input/Output Timing - Peak Minute

A.1 Communications Channel

Input Characters	90,000
Output Characters	<u>90,000</u>
Total Characters	<u>180,000</u>
x 7.5 Microseconds each	1.170 Seconds

A.2 Drum Channel

Input Blocks	1,061.80
Output Blocks	<u>1,061.80</u>
Total Blocks	<u>2,123.60</u>
x 30 Words/Block	63,708.00 Words

Input Messages	42.42
x 50 Words of Control/Message	<u>2,121.00</u> Words
Total Words	<u>65,829.00</u>
x 7.5 Microseconds each	0.494 Seconds

A.3 Peripheral Storage Channel

Journal Storage	42.42
Input Messages	5,090.40 Words
x 120 Words of Control	

Reference Storage	3.10
Input Messages	77.50
Input Blocks	<u>2,325.00</u> Words
x 30 Words/Block	<u>7,415.40</u>
Total Words	0.056 Seconds
x 7.5 Microseconds each	

A.4 Total Input/Output Channel Time

Communication Channel	1.170 Seconds
Drum Channel	0.494 Seconds
Peripheral Channel	<u>0.056</u> Seconds
Total	1.620 Seconds

B. Drum Timing - Peak Minute

B.1 Access Time

Input Blocks	1,061.80	
Output Blocks	<u>1,061.80</u>	
Total Blocks	2,123.60	
x 1 Reference/Block		2,123.60 References
Input Messages	42.42	
x 2 Reference/Messages for Control	<u>84.84</u>	References
Total References	2,208.44	
x 17 Millisecond/Access		37.543 Seconds

B.2 Transfer Time

Input Blocks	1,061.80	
Output Blocks	<u>1,061.80</u>	
Total Blocks	2,123.60	
x 30 Words/Block		63,708.00 Words
Input Messages	42.42	
x 50 Words of Control/Message	<u>2,121.00</u>	Words
Total Words	65,829.00	
x 16.5 Microseconds/Word		1.146 Seconds

B.3 Total Drum Time

Access Time	37.543	Seconds
Transfer Time	<u>1.146</u>	Seconds
Total	38.689	Seconds

C. Magnetic Tape Unit - Peak Minute

C.1 Tape Start Time

Input Messages	42.42	
x 4 Journal Entries/Message	169.68	Starts
Input for Reference Messages	3.10	
Blocks	77.50	
x 1 Start/Block	<u>77.50</u>	Starts
Total Starts	247.18	
x 9.5 Milliseconds/Start		2.348 Seconds

C.2 Tape Transfer Time

Input Messages	42.42	
x 360 Characters of Journal	15,291.20	Characters

Reference Messages	3.10
x 2000 Characters	<u>6,200.00</u> Characters
Total Characters	21,491.20 Characters
x 29.3 Microseconds	0.630 Seconds

C.3 Total Tape Time

Tape Start	2.348 Seconds
Tape Transfer	<u>0.630</u> Seconds
Total	2.978 Seconds

Note: If the UNISERVO Magnetic Tape Units are not used and all Reference and Journal Storage entries are kept on the MH-160 Magnetic Drum add 1.523 seconds to item B.3 above for drum time for Journal Storage entries. Since the message is already contained on the intransit storage, there is no need of a duplicate recording for a Reference Storage. The Intransit Storage and Reference Storage are therefore, one in the same.

D. Additional Drum Time for Journal Storage

D.1 Access Time

Input Messages	42.42 Messages
x 2 references/message	84.84 References
Total Journal entry references	84.84 References
x 17 milliseconds/reference	1.44 Seconds

D.2 Transfer Time

Input Messages	42.42 Messages
x 360 characters/entry	15,291.20 Characters
Total characters	15,291.20 Characters
Total words	5,097.10 Words
x 16.5 microseconds/word	.084 Seconds

D.3 Total Drum Time

Access Time from B.1	37.543 Seconds
Access Time from D.1	1.44 Seconds
Transfer Time from B.2	1.146 Seconds
Transfer Time from D.2	<u>.084</u> Seconds
Total	40.213 Seconds

TABLE 5-4

Program Timing Peak MinuteA. Block Parity Check or
Generate.

Blocks from Mode I	
For Concentration	334.93
For Distribution	83.47
Blocks from Mode V	
For Concentration	179.82
For Distribution	44.95
Block from Trunk	
For Distribution	<u>418.63</u>
Total Blocks	1,061.80
Times 442.5 Microseconds Per Block	0.470 Seconds

B. Character Parity Check, Control Code Check, Invalid Check

Characters from Mode I	
For Concentration	28,129.44
For Distribution	7,033.36
Characters from Mode V	
For Concentration	14,385.60
For Distribution	3,596.40
Characters from Trunks	
For Distribution	<u>35,162.80</u>
Total Characters	88,304.60
Divided by 6 Characters Per Buffer	14,717.43 Buffers
Times 610 Microseconds Per Buffer	8,978 Seconds

C. Data Packing

Total Characters	88,304.60
Divided by 6 Characters Per Buffer	14,717.43 Buffers
Times 510 Microseconds Per Buffer	7.506 Seconds

D. Miscellaneous Housekeeping

Messages from Mode I		
For Concentration	13.39	
For Distribution	3.30	
Messages from Mode V		
For Concentration	7.19	
For Distribution	1.80	
Messages from Trunks		
For Distribution	<u>16.74</u>	
Total Messages	42.42	
Times 2000 Instructions Per Message	84,840	Instructions
Times 12.5 Microseconds Per Instruction	1.061	Seconds

E. Totals in Seconds Per Peak Minute

Input/output Core Time	1.620
Block Parity	0.470
Character Parity Checks	8.978
Data Buffer Packing	7.506
Data Buffer Unpacking (Same as Packing)	7.506
Miscellaneous Housekeeping	1.061
Total Seconds Used	27.141

TABLE 5-5
Storage Requirements - Core
Minor Switching Center

Storage Requirements

Core Storage

A. Communications Line Buffers

Numbers of Lines	26
Times 2 for FDX	52
Times 6 words per line	312
Times 2 for standby	624 Words

B. Drum Packing Buffers

Number of lines	26
Times 2 for FDX	52
Times 30 words per line	1,560
Times 2 for Standby	3,210 Words

C. CLT Control Tables

Number of CLT's	26
Times 30 words of control	780 Words

D. Tables

Field Data Character Check	256 Words
ASCII to fielddata and return	256 Words
Preselect Message Queue	104 Words
Drum Control Queue	1,000 Words-Est.
Total Non-program Storage	6,140 Words
Executive Storage	4,096 Words
Operating Program Storage	4,096 Est.
Total Storage in Use	14,332
Storage Provided	16,384
Expansion Storage	2,052
Using 174 Words Per Line	11 Lines

TABLE 5-6
Storage Requirement - Core
Concentrator Center

Concentrator/Distributor

A. Communications Line Buffers

Number of Lines	26
Times 2 for FDX	52
Times 6 words per line	312
Times 2 for standby	624 Words

B. Drum Packing Buffers

Number of lines	26
Times 2 for FDX	52
Times 30 words per line	1,560
Times 2 for Standby	3,210 Words

C. CLT Control Tables

Number of CLT's	26
Times 30 words of control	780 Words

D. Tables

Field Data Character Check	256 Words
ASCII to fielddata and return	256 Words
Preselect Message Queue	104 Words
Drum Control Queue	<u>800</u> Words-Est.
Total Non-program Storage	5,940 Words

E. Program

Input/Output Coordinator	300 Words
Operating Program Storage	<u>1,400</u> Est.
Total Storage in Use	7,640
Storage Provided	8,192
Expansion Storage	552